

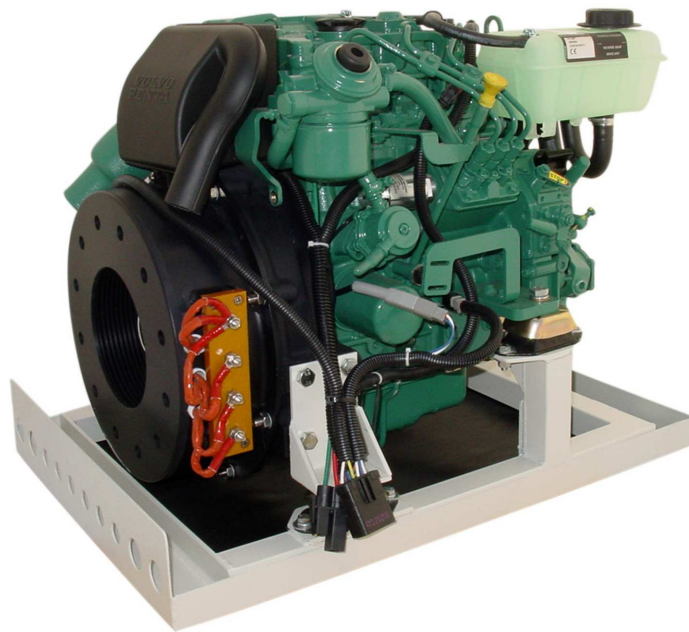

Installation Manual Volvo Penta - Engine



Welcome Aboard

Polar DC Generators and Volvo Penta marine engines are used all over the world today. They are used in all possible operating conditions for professional as well as leisure purposes.

Polar DC Marine is becoming a symbol of reliability, technical innovation, performance and long service life. We also believe that this is what you demand and expect of your Polar DC Marine generator .

Please read this operator's manual thoroughly and consider the advice we provide on operation and maintenance before you cast off on your voyage so that you will be ensured of fulfilling your expectations.

Installation

Marine Diesel Engines

D1-13, D1-20, D1-30

D2-40, D2-55, D2-75

Contents

Safety precautions	2
General information	5
Conversion factors	7
Special tools	8
Installation drawings	8
Engine installation	9
Engine inclination	9
Flexible shaft seal	10
Rigid shaft seal	10
Fitting of reverse gear and S-drive	11
S-drive insulation	11
Rubber mounts	12
Propeller shaft system	13
Front end power take-off	15
Cooling system	19
Exhaust system	24
Engine room ventilation	26
Soundproofing	28
Fuel system	30
Electrical system	32
Connection of battery cables	36
Controls	38
S-drive installation	41
Preparation	41
Cutting and fibreglassing of engine bed	43
Installation of drive and engine	46
Fitting of the rubber seal	48
Installation of propeller	49
Oil quality and filling	50
References to Service Bulletins	52

Safety precautions

Introduction

This Installation Manual contains the information you will need to install your Volvo Penta product correctly. Check that you have the correct Installation Manual.

Read the *Safety precautions* and the *General information* in the installation manual carefully before servicing or operating the engine.

Important

The following special warning symbols are found in this manual and on the engine.

 **WARNING!** Danger of personal injury, damage to property or mechanical malfunction if the instructions are not followed.

 **IMPORTANT!** Possible damage or mechanical malfunction in products or property.

NOTE! Important information to facilitate work processes or operation.

Below is a list of the risks that you must always be aware of and the safety measures you must always carry out.

 Plan in advance so that you have enough room for safe installation and (future) dismantling. Plan the engine compartment (and other compartments such as the battery compartment) so that all service points are accessible. Make sure it is not possible to come into contact with rotating components, hot surfaces or sharp edges when servicing and inspecting the engine. Ensure that all equipment (pump drives, compressors for example) has protective covers.

 Make sure the engine is immobilized by not connecting the electrical system or turning off the power supply to the engine at the main switch (breakers), and locking the switch (breakers) in the OFF position for as long as work continues. Set up a warning notice at the engine control point or helm.

 As a rule, no work should be done on a running engine. However, some work e. g. adjustments, requires a running engine. Approaching an engine that is running is a safety risk. Loose clothing or long hair can fasten in rotating parts and cause serious personal injury. If working in proximity of a running engine, careless movements or a dropped tool can result in personal injury. Take precautions to avoid hot surfaces (exhaust pipes, turbochargers, charge air manifolds, starting elements etc.) and hot liquids in supply lines and hoses in engines that are running or have just been turned off. Reinstall all protective parts removed during service operations before starting work on the engine.

 Ensure that the warning or information decals on the product are always visible. Replace decals which are damaged or painted over.

 Turbocharged engines: Never start the engine without installing the air cleaner. The rotating compressor turbine in the turbocharger can cause serious personal injury. Foreign objects entering the intake ducts can also cause mechanical damage.

 Never use start spray in the air intake. Use of such products could result in an explosion in the air intake pipe. There is a danger of personal injury.

 Do not open the filler cap for the engine coolant (freshwater cooled engines) when the engine is hot. Steam or hot engine coolant can be ejected and any pressure in the system will be lost. Open the filler cap slowly and release coolant system pressure (freshwater cooled engines). If the filler cap or drain cock must be opened, or if a plug or engine coolant line must be removed on a hot engine, steam or hot coolant can be ejected.

 Hot oil can cause burns. Avoid skin contact with hot oil. Make sure that the oil system is released before starting work on it. Never start or run the engine without the oil filler cap in place because of the risk of oil being ejected.

- ⚠ If the boat is in the water, stop the engine and close the sea cock before carrying out operations on the cooling system.
- ⚠ Only start the engine in an area that is well ventilated. Beware, the exhaust gas is poisonous to breathe in. When operating in an enclosed space, use exhaust extraction to lead the exhaust and crankcase gases away from the workplace.
- ⚠ Always wear protective goggles if there is a risk of splinters, grinding sparks and splashes from acid or other chemicals. Your eyes are extremely sensitive and an injury to them can result in loss of sight!
- ⚠ Avoid skin contact with oil! Long term or repeated skin contact with oil can lead to the loss of natural oils from the skin. This leads to irritation, dry skin, eczema and other skin problems. Old oil is more dangerous to your health than new. Use protective gloves and avoid oil-soaked clothes and rags. Wash regularly, especially before meals. Use special skin creams to help clean and to stop your skin drying out.
- ⚠ Most chemicals intended for the product (engine and reverse gear oils, glycol, gasoline and diesel), or chemicals intended for the workshop (degreasing agent, paints and solvents) are harmful to your health. Read the instructions on the packaging carefully! Always follow protective measures (using a protective mask, goggles, gloves etc.). Make sure that other personnel are not unknowingly exposed to harmful substances, in the air that they breathe for example. Ensure good ventilation. Dispose of used and excess chemicals as directed.
- ⚠ Be extremely careful when tracing leaks in the fuel system and when testing injectors. Wear protective goggles. The jet from an injector is under very high pressure and fuel can penetrate deep into tissue, causing serious injury with a risk of blood poisoning.
- ⚠ All fuels and many chemicals are flammable. Keep away from naked flames or sparks. Gasoline, some solvents and hydrogen from batteries in the correct proportions with air are very inflammable and explosive. Do not smoke! Maintain good ventilation and take the necessary safety measures before welding or grinding in the vicinity. Always keep a fire extinguisher accessible in the workplace.
- ⚠ Store oil and fuel-soaked rags and old fuel and oil filters properly. Oil-soaked rags can ignite spontaneously in certain circumstances. Old fuel and oil filters are environmentally harmful and should be sent for destruction to a proper refuse station for environmentally harmful material for destruction.
- ⚠ Ensure that the battery compartment is designed according to current safety standards. Never allow an open flame or electric sparks near the battery area. Never smoke near to the batteries. The batteries give off hydrogen gas during charging which when mixed with air can form an explosive gas. This gas is easily ignited and highly volatile. Incorrect connection of the battery can cause sparks sufficient to cause an explosion with resulting damage. Do not shift the connections when attempting to start the engine (spark risk) and do not lean over any of the batteries.
- ⚠ Always ensure that the Plus (positive) and Minus (negative) battery leads are correctly installed on the corresponding terminal posts on the battery. Incorrect installation can result in serious damage to the electrical equipment. Refer to the wiring diagrams.
- ⚠ Always use protective goggles when charging and handling the batteries. The battery electrolyte contains extremely corrosive sulphuric acid. If this should come in contact with the skin, immediately wash with soap and plenty of water. If battery acid comes in contact with the eyes, flush immediately with water and obtain medical assistance.
- ⚠ Turn the engine off and turn off the power at the main switches (breakers) before carrying out work on the electrical system.

 Clutch adjustments must be carried out with the engine turned off.

 Use the lifting eyes fitted on the engine/reverse gear when lifting the drive unit. Always check that the lifting equipment used is in good condition and has the load capacity to lift the engine (engine weight including reverse gear and any extra equipment installed).

Use an adjustable lifting beam to ensure safe lifting and avoid damage to components installed on the top of the engine. All chains and cables must run parallel to each other and as perpendicular as possible to the upper side of the engine.

If extra equipment is installed on the engine which alters its center of gravity a special lifting device is required to obtain the correct balance for safe handling.

Never carry out work on an engine suspended on a hoist.

 Never work alone when installing heavy components, even when using secure lifting equipment such as a lockable block and tackle. Most lifting devices require two people, one to see to the lifting device and one to ensure that the components do not get caught and damaged.

 The components in the electrical system, the ignition system (gasoline/petrol engines) and in the fuel system on Volvo Penta products are designed and manufactured to minimize risks of fire and explosion. Engines should not run in environments containing explosive media.

 Always use fuels recommended by VolvoPenta. Refer to the Owner's Manual. Use of lower quality fuels can damage the engine. On a diesel engine poor quality fuel can cause the fuel control rack to stick causing the engine to overspeed with resulting risk of damage to the engine and personal injury. Poor fuel quality can also lead to higher maintenance costs.

General information

About the Installation Manual

This publication is intended as a guide for the installation of Volvo Penta D1 and D2 engines, inboard and S-drive. The publication is not comprehensive and does not cover every possible installation, but is to be regarded as recommendations and guidelines applying to Volvo Penta standards. Detailed Installation Instructions are included in most of the accessory kits.

These recommendations are the result of many years of practical experience of installations from all over the world. Departures from recommended procedures etc. can be necessary or desirable, however, in which case the Volvo Penta organization will be glad to offer assistance in finding a solution for your particular installation.

It is the sole responsibility of the installer to ensure that the installation work is carried out in a satisfactory manner, it is operationally in good order, the approved materials and accessories are used and the installation meets all applicable rules and regulations.

This Installation Manual has been published for professionals and qualified personnel. It is therefore assumed that persons using this book have basic knowledge of marine propulsion systems and are able to carry out related mechanical and electrical work.

Installation of electrical systems shall only be carried out by a professional boat electrician.

Only components, cables, connections etc, delivered or approved by the manufacturer may be used. The manufacturer will accept no responsibility what so ever if this requirement is ignored.

Volvo Penta continuously upgrades its products and reserves the right to make changes. All the information contained in this manual is based on product data available at the time of print. Notification of any important modifications to the product causing changes to installation methods after this date will be made in Service Bulletins.

Plan installations with care

Great care must be taken in the installation of engines and their components if they are to operate perfectly. Always make sure that the correct specifications, drawings and any other data are available before starting work. This will allow for correct planning and installation right from the start.

Plan the engine room so that it is easy to carry out routine service operations involving the replacement of components. Compare the engine Service Manual with the original drawings showing the dimensions.

It is very important when installing engines that no dirt or other foreign matter gets into the fuel, cooling, intake or turbocharger systems, as this can lead to faults or engine seizure. For this reason the systems must be sealed. Clean supply lines and hoses before connecting them to the engine. Only remove protective engine plugs when making a connection to an external system.

Certified engines

The manufacturer of engines certified for national and local environmental legislation (Lake Constance for example) pledges that this legislation is met by both new and currently operational engines. The product must compare with the example approved for certification purposes. So that Volvo Penta, as a manufacturer, can pledge that currently operational engines meet environmental regulations, the following must be observed during installation:

- Servicing of ignition, timing and fuel injection systems (gasoline) or injector pumps, pump settings and injectors (diesel) must always be carried out by an authorised Volvo Penta workshop.
- The engine must not be modified in any way except with accessories and service kits developed for it by Volvo Penta.
- Installation of exhaust pipes and air intake ducts for the engine compartment (ventilation ducts) must be carefully planned as its design may affect exhaust emissions.
- Seals may only be broken by authorised personnel.

 **IMPORTANT!** Use only Volvo Penta Genuine Parts.

Using non-genuine parts will mean that AB Volvo Penta will no longer take responsibility for the engine meeting the certified design.

All damage and costs caused by the use of non-genuine replacement parts will not be covered by Volvo Penta.

Seaworthiness

It is the boat builder's duty to check that the security requirements apply to the market in which the boat is sold. In the USA for example, these are the US Federal Regulations for pleasure boats described in Title 46. The requirements described below apply to the EU principles. For information and detailed descriptions of the safety requirements that apply to other markets, contact the authority for the country

concerned.

As of June 16 1998, pleasure boats and certain associated equipment marketed and used within the EU must bear CE labels to confirm that they meet the safety requirements stipulated by the European Parliament and Council of Europe's directive for pleasure boats. The normative requirements can be found in the standards drawn up to support the directive's objective of uniform safety requirements for pleasure boats in EU countries.

Certificates that grant the right for CE label use and confirm that boats and equipment meet safety requirements are issued by approved notified bodies. In many Member States the classification societies have become the notified bodies for pleasure boats, e.g. Lloyd's Register, Bureau Veritas, Registro Italiano Navale, Germanischer Lloyd, etc.

In many cases completely new institutions have been approved as notified bodies. The directive also allows boat builders and component manufacturers to issue assurances of compliance with the requirements of the directive. This requires the manufacturer to store the prescribed product documentation in a place that is accessible to the monitoring authority for at least ten years after the last product is produced.

Life boats and boats for commercial activities are approved by classification societies or by the navigation authority for the boat's registered country.

Joint liability

Each engine consists of many components working together. One component deviating from its technical specification can cause a dramatic increase in the environmental impact of an engine. It is therefore vital that systems that can be adjusted are adjusted properly and that Volvo Penta Genuine Parts as used.

Certain systems e.g. components in the fuel system may require special expertise and special test equipment. Some components are sealed at the factory for environmental reasons. No work should be carried out on sealed components except by authorised personnel.

Remember that most chemical products damage the environment if used incorrectly. Volvo Penta recommends the use of biodegradable degreasing agents for cleaning engine components, unless otherwise indicated in a Workshop Manual. Take special care when working on board boats to ensure that oil and waste are taken for destruction and not accidentally pumped into the environment with bilgewater.

Conversion factors

Metric to U.S. or IMP. conversion factors:

U.S. or IMP. to metric conversion factors:

	To convert from	To	Multiply by	To convert from	To	Multiply by
Length	mm	inch	0.03937	inch	mm	25.40
	cm	inch	0.3937	inch	cm	2.540
	m	foot	3.2808	foot	m	0.3048
Area	mm ²	sq.in.	0.00155	sq. in.	mm ²	645.2
	m ²	sq. ft.	10.76	sq. ft.	m ²	0.093
Volume	cm ³	cu. in.	0.06102	cu. in.	cm ³	16.388
	litre, dm ³	cu. ft.	0.03531	cu. ft.	litre, dm ³	28.320
	litre, dm ³	cu. in.	61.023	cu. in.	litre, dm ³	0.01639
	litre, dm ³	imp. gallon	0.220	imp. gallon	litre, dm ³	4.545
	litre, dm ³	U.S. gallon	0.2642	U.S. gallon	litre, dm ³	3.785
	m ³	cu. ft.	35.315	cu.ft.	m ³	0.0283
Force	N	lbf	0.2248	lbf	N	4.448
Weight	kg	lb.	2.205	lb.	kg	0.454
Power	kW	hp (metric) ¹⁾	1.36	hp (metric) ¹⁾	kW	0.735
	kW	bhp	1.341	bhp	kW	0.7457
	kW	BTU/min	56.87	BTU/min	kW	0.0176
Torque	Nm	lbf ft	0.738	lbf ft	Nm	1.356
Pressure	Bar	psi	14.5038	psi	Bar	0.06895
	MPa	psi	145.038	psi	MPa	0.006895
	Pa	mm Wc	0.102	mm Wc	Pa	9.807
	Pa	in Wc	0.004	in Wc	Pa	249.098
	KPa	in Wc	4.0	in Wc	KPa	0.24908
	mWg	in Wc	39.37	in Wc	mWg	0.0254
Energy	kJ/kWh	BTU/hph	0.697	BTU/hph	kJ/kWh	1.435
Work	kJ/kg	BTU/lb	0.430	BTU/lb	kJ/kg	2.326
	MJ/kg	BTU/lb	430	BTU/lb	MJ/kg	0.00233
	kJ/kg	kcal/kg	0.239	kcal/kg	kJ/kg	4.184
Fuel consump.	g/kWh	g/hph	0.736	g/hph	g/kWh	1.36
	g/kWh	lb/hph	0.00162	lb/hph	g/kWh	616.78
Inertia	kgm ²	lbft ²	23.734	lbft ²	kgm ²	0.042
Flow, gas	m ³ /h	cu.ft./min.	0.5886	cu.ft./min.	m ³ /h	1.699
Flow, liquid	m ³ /h	US gal/min	4.403	US gal/min	m ³ /h	0.2271
Speed	m/s	ft./s	3.281	ft./s	m/s	0.3048
	mph	knots	0.869	knots	mph	1.1508
Temp.	°F=9/5 x °C+32			°C=5/9 x (°F-32)		

1) All hp figures stated in the catalogue are metric.

Special tools

Engine bed tool

Engine bed tool for D1-series and D2-series can be produced locally. Contact Volvo Penta organisation for drawings of a suitable tool.

Installation drawings

Installation drawings regarding the D1 and D2 engines are available at:
<http://www.volvopenta.com>.

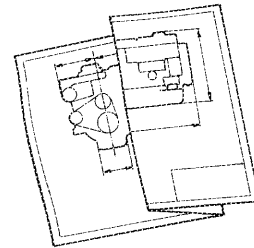

Engine installation

Engine inclination

Flywheel down

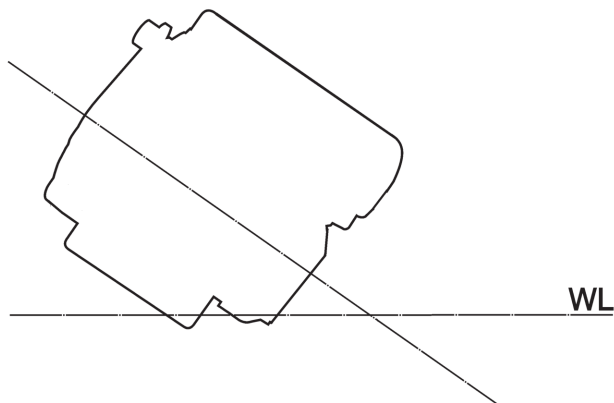

Flywheel up

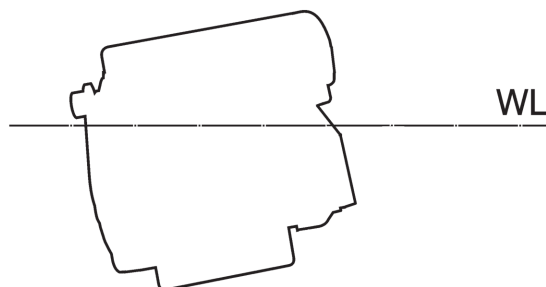

Max. inclination

Engine	Static		Under way		
	Flywheel down	Flywheel up	down	Flywheel up	Sideways
D1-ser.	15°	0°	25°	0°	35°
D2-40	15°	0°	25°	0°	35°
D2-55/75	15°	0°	35°	10°	35°

Service accessibility

When you design the engine installation, always pay attention to the access needed for correct engine service. Also ensure that the complete engine can be removed without damage to the boat structure.

There must also be sufficient space for the sound proofing material.

NOTE! See installation drawing for space required to lift out engine.

NOTE! Minimum recommended access two sides, front and starboard.

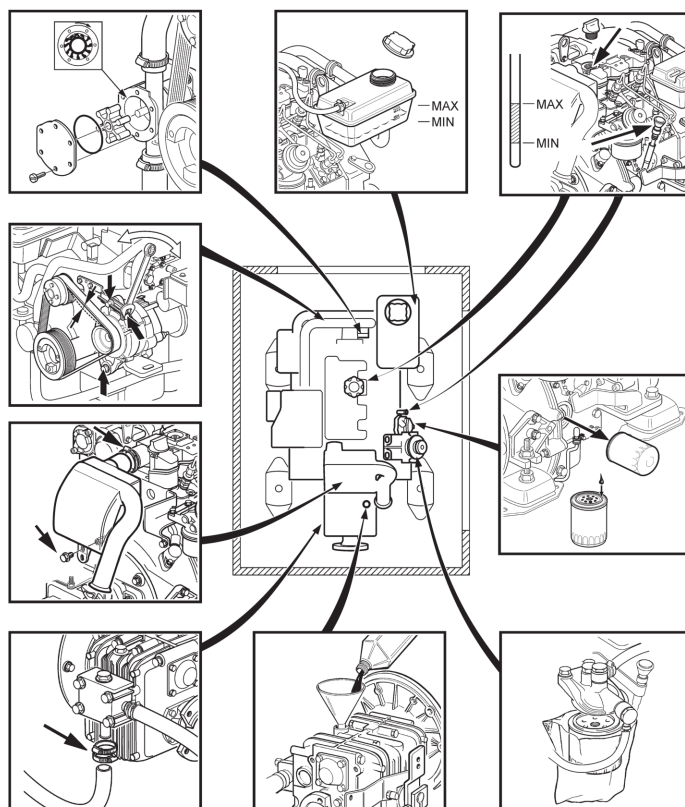

Flexible shaft seal

Volvo Penta water lubricated rubber type

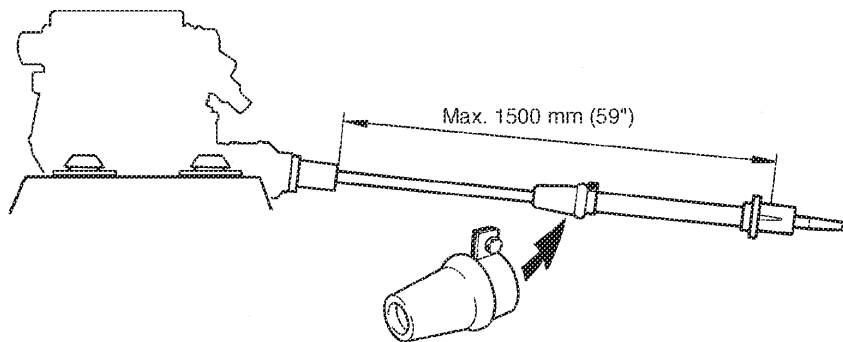

Grease lubricated shaft seal

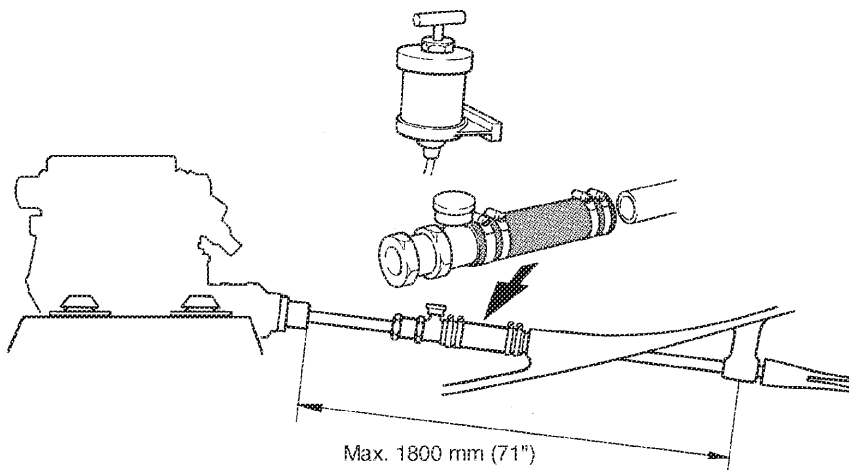

When using a flexible shaft seal and flexible engine suspension, a flexible shaft coupling must **not** be fitted.

Rigid shaft seal

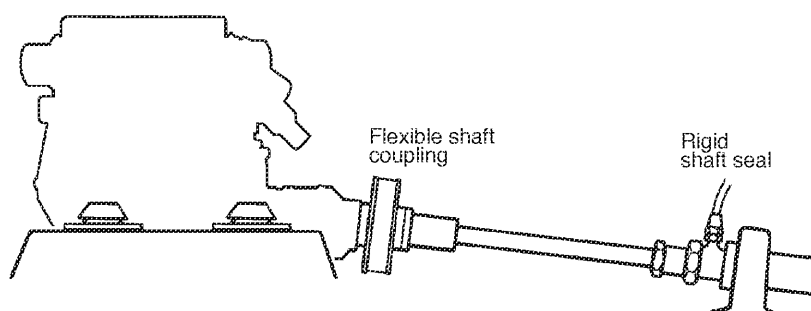

When using a rigid shaft seal and flexible engine suspension, a flexible shaft coupling must be fitted.

Fitting of reverse gear and S-drive

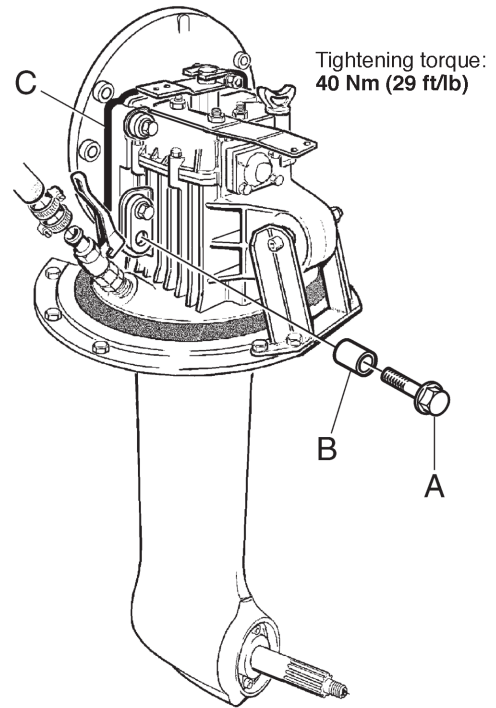
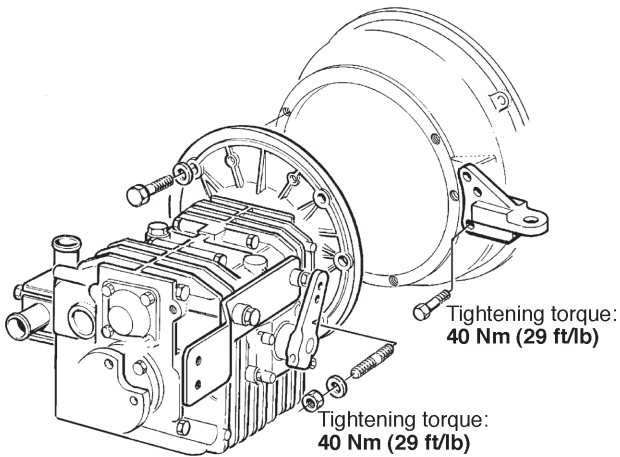

NOTE! There is no insulation between engine and transmission except on S-drives.

S-drive insulation

The 130S/SR and 150S/SR has an insulation located in the drive. Between the adapter plate and the upper housing is a insulating gasket (C) installed.

One of the lower two bolts (A) has an insulating bushing (B) fitted. This bolt and bushing are secured during transportation by a nut.

Electrical insulation between engine and flywheel casing/power transmission.

⚠ IMPORTANT! The S-drive must on no account be grounded. Grounding the S-drive may cause serious damage due to galvanic corrosion.

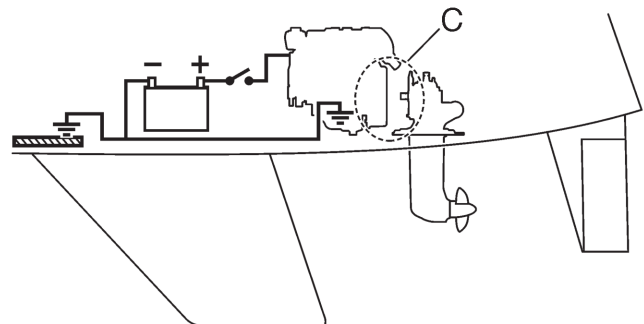

Check insulation

Connect a measuring device to the bolt on the upper housing and the grounding device connection on the engine. The result should be above 100 kΩ. If the measured value is below 100kΩ the installation needs to be reviewed. Please contact your Volvo Penta dealer.

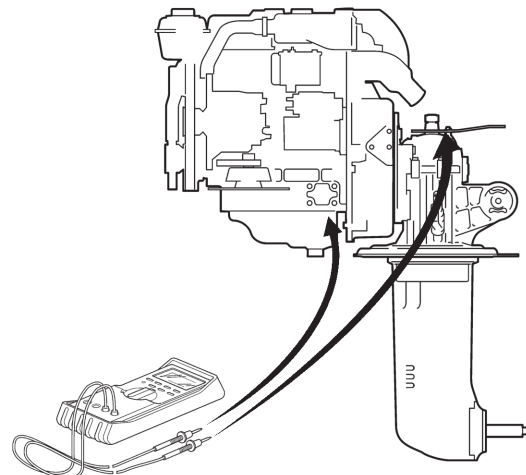

Rubber mounts

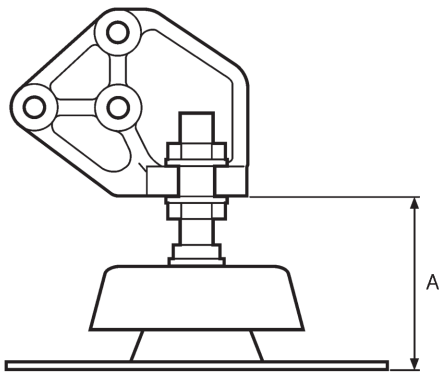

D1-20 and D1-30, Inboard

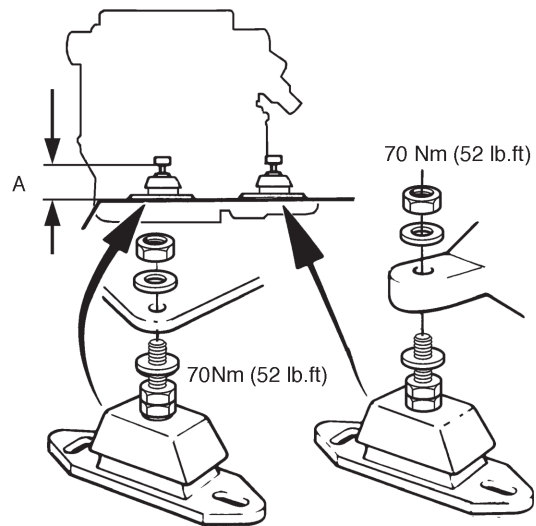
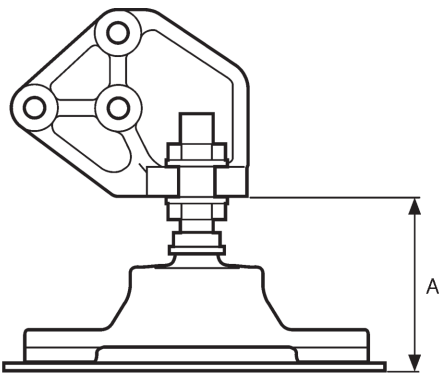

Tightening torque

Tightening torque, rubber mounts, all D1 and D2 engines: **70 Nm (52 lb.ft)**

A- measurement, D1 and D2

Unloaded conditions

Transmission	Front mm (")	Rear mm (")
Reverse gear	85±8 (3.3±0.3)	85±8 (3.3±0.3)
S-drive	Fixed	Fixed

NOTE! Make sure that the rubber mounts are installed so that no pre-load or side forces occur when the engine has been installed and aligned with the propeller shaft.

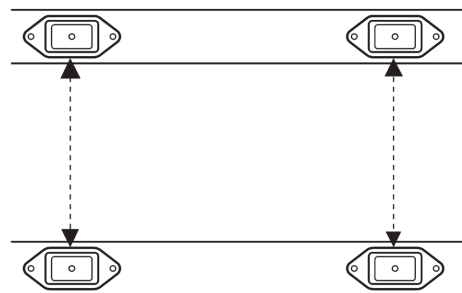
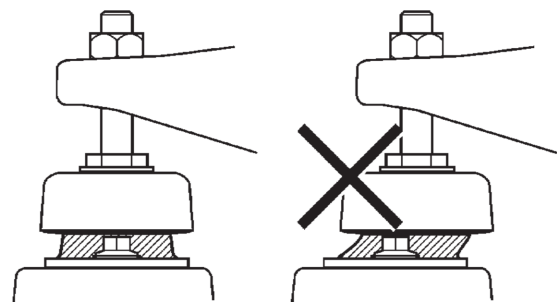

Compare front and rear mounts sidwise in pairs. Adjust if necessary.

Propeller shaft system

Dimensions

Engine	Reverse gear ratio	Shaft diameter, min. mm
(**)*		
D1-13	2.4:1–2.7:1	∅=25 (1.0)
D1-20	2.4:1–2.7:1	∅=25 (1.0)
D1-30	2.4:1–2.7:1–2.6:1	∅=25 (1.0)
D2-40	2.1:1–2.6:1	∅=30 (1.2)
D2-55	2.2:1–2.7:1	∅=30 (1.2)
D2-75	2.1:1–2.3:1	∅=30 (1.2)
D2-75	2.4:1–2.8:1	∅=35 (1.4)

* With Volvo Penta standard material

Propeller shaft coupling

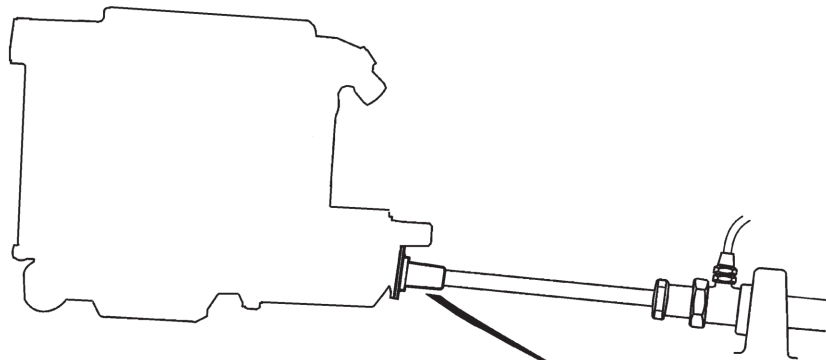

Reverse gear flange

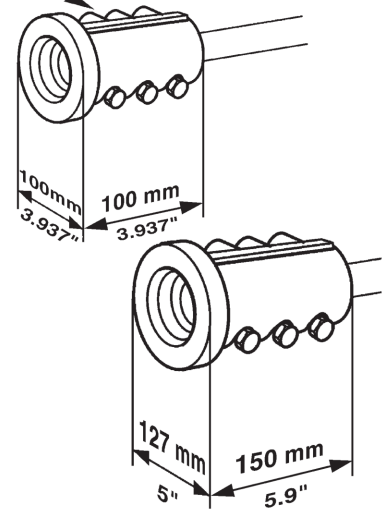
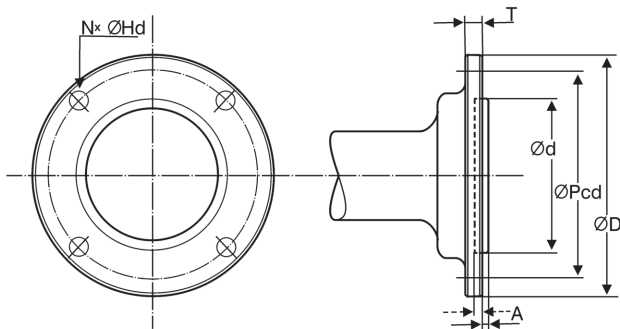

Transmission mm (inch)	D	Pcd	d	T	A	N x Hd
MS10 A/L	102 (4.02)	80 (3.15)	60 (2.36) H8	12 (0.47)	3.5 (0.14)	4x11.5 (0.45)
MS15 A/L	102 (4.02)	80 (3.15)	60 (2.36) H8	12 (0.47)	3.5 (0.14)	4x11.5 (0.45)
MS25 A/L	102 (4.02)	80 (3.15)	60 (2.36) H8	12 (0.47)	3.5 (0.14)	4x11.5 (0.45)
HS25A	127 (5.00)	108 (4.25)	63.5 (2.50) H8		10 (0.39)	–4* (–0.16)* 4x11.5 (0.45)

* Female configuration

Reverse gear ratios

Reverse gear	Ratio RH	Ratio LH
MS10L	2.35:1	2.26:1
MS10L	2.72:1	2.26:1
MS10A	2.35:1	2.70:1
MS10A	2.72:1	2.70:1
MS15L	2.14:1	1.95:1
MS15L	2.63:1	1.95:1
MS15A	2.14:1	1.95:1
MS15A	2.63:1	1.95:1
MS25L	2.27:1	2.10:1
MS25L	2.74:1	2.72:1
MS25A	2.23:1	2.74:1
MS25A	2.74:1	2.74:1
HS25A	2.29:1	2.29:1
HS25A	2.71:1	2.71:1
130S/SR	2.19:1	
2.19:1		
150S/SR	2.19:1	
2.19:1		

Alignment

Before the propeller shaft is connected to the reverse gear flange, check to make sure that the flanges are parallel.

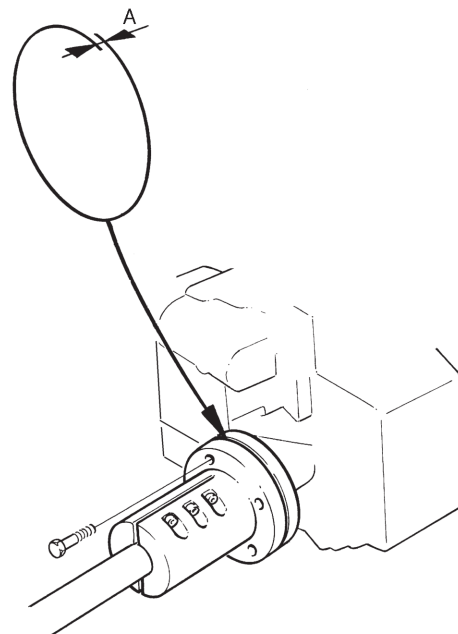

Move the flanges together so that the guide engages. Then, with the flanges pressed together, check that they are parallel and that a 0.10 mm (0.004") feeler gauge cannot be inserted anywhere inbetween them (A).

Then turn the flanges 90°, 180° and 270° and repeat this check at the new positions. Make sure that the flanges are well pressed together during the entire check. If the deviation is **greater than 0.10 mm (0.004")**, the alignment must be re adjusted.

Remove any aids being used and connect the shaft to the reverse gear flange, or flexible coupling.

⚠ IMPORTANT! The alignment should be re-checked again a few days after the launch when the boat is completed (extra critical with sail-boats).

Front end power take-off

⚠ IMPORTANT! D1-13 engines only:
Power take-off is not allowed.

Front mounted universal bracket

This universal bracket, with adjustable attachments, allows air conditioning compressors or hydraulic pumps etc. to be installed and operated. The kit contains the bracket and fittings.

The table below shows the width and length of the mounting plate.

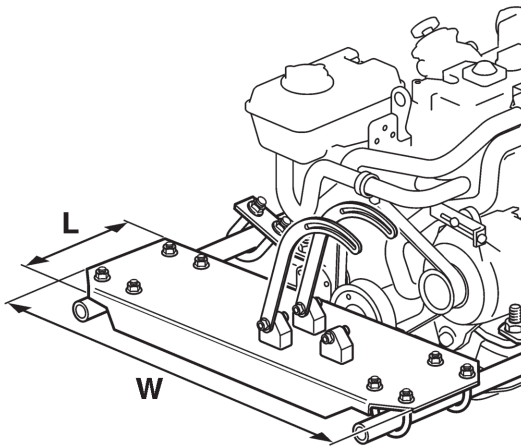

Engine	Width, L mm (")	Length, W mm (")
D1, D2-40	582 (22.9)	140 (5.5)
D2-55, D2-75	634 (25.0)	170 (6.7)

The increase in length of the engine installation depends on how the bracket is installed. Auxiliary equipment can increase the length further.

NOTE! Additional rear brackets are required when installing a universal bracket on a S-drive engine. Rear brackets are included in a separate kit.

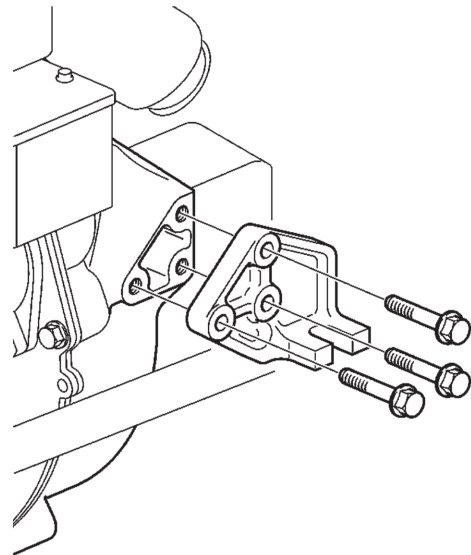

Top mounted extra alternator

Added installation length (A): **82 mm (3.2")**

Added installation width (B): **18 mm (0.7")**

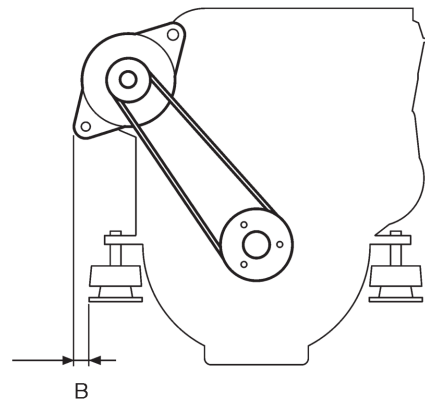
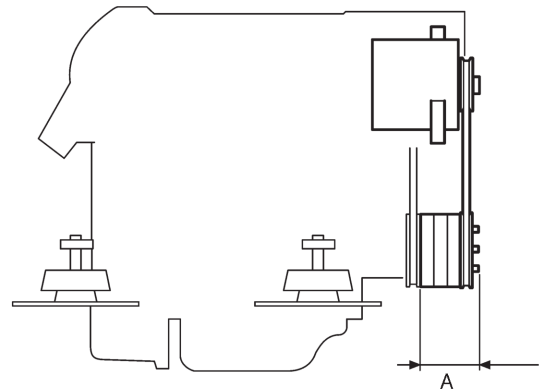

Extra pulleys (power take-off)

D2-55 and D2-75

⚠ IMPORTANT! D1-13 engines only:
Power take-off is not allowed.

Auxilliary equipment driven by the drive belt on the crankshaft of the engine increase the load on the crankshaft. Therefore it is important to review the position and power requirement of the power take-off.

Maximum power supplied depends on the alignment of the belt, the belt type and the engine type.

Pulley groove alternatives:

- HC50
- Multi-V

Pulley HC50

Number of grooves: 1

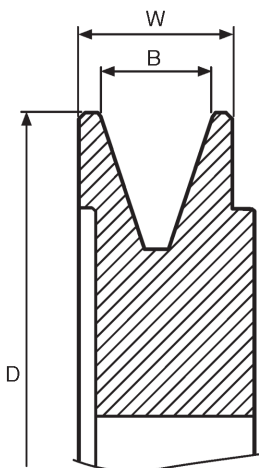
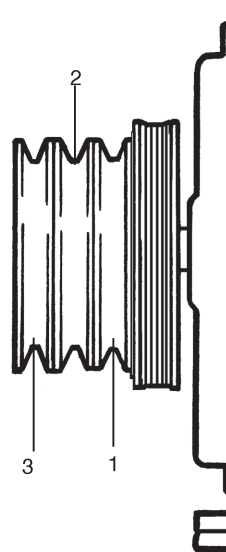

NOTE! The following table only gives general advice about the power which can be taken via a maximum of three extra belt grooves on the crankshaft nose.

Engine	Pulley 1	2	3
	kW/pulley*		
D2-55	6.8	6.8	6.8
D2-75	6.8	6.8	6.8

Overall diameter (D)	120+0.5 mm (4.72+0.02")
Width (W) (0.71±0.01")	18.0±0.25 mm
Belt width (B)	12.7 mm (0.50")

D1-20, D1-30 and D2-40

NOTE! The maximum permissible torque shown in the figures can be applied for one pulley at a maximum distance from the cylinder block corresponding to 4 pulleys or 3 spacers and one pulley. If several pulleys are to be used the permissible torque has to be divided so that torque limitations are not exceeded.

D1-20

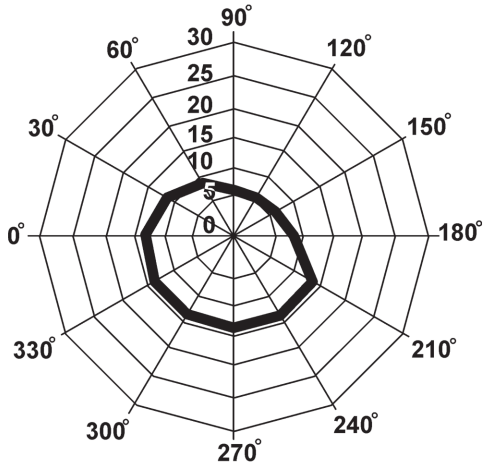

Permissible torque

α°	Nm
0°	13.2
30°	11.8
60°	7.7
90°	6.0
120°	5.6
150°	6.4
180°	8.6
210°	13.2
240°	13.2
270°	13.2
300°	13.2
330°	13.2

D1-30

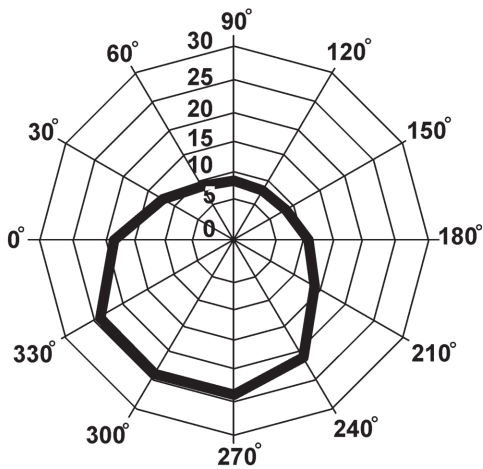

Permissible torque

α°	Nm
0°	18.0
30°	12.9
60°	9.4
90°	7.8
120°	7.5
150°	8.7
180°	11.0
210°	14.7
240°	21.1
270°	24.0
300°	24.6
330°	24.1

D2-40

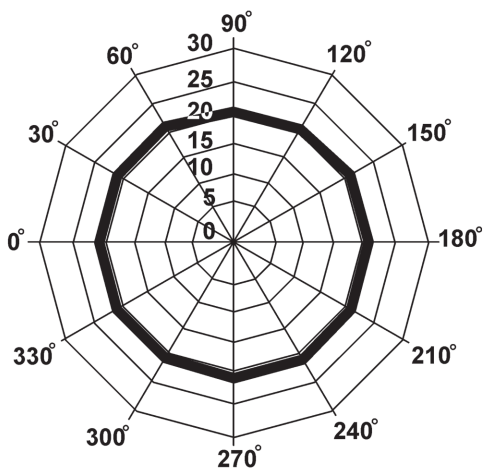

Permissible torque

α°	Nm
0°	21.7
30°	21.7
60°	21.7
90°	21.2
120°	20.8
150°	21.7
180°	21.7
210°	21.7
240°	21.7
270°	21.7
300°	21.7
330°	21.7

Example - D1-30 - One pulley used

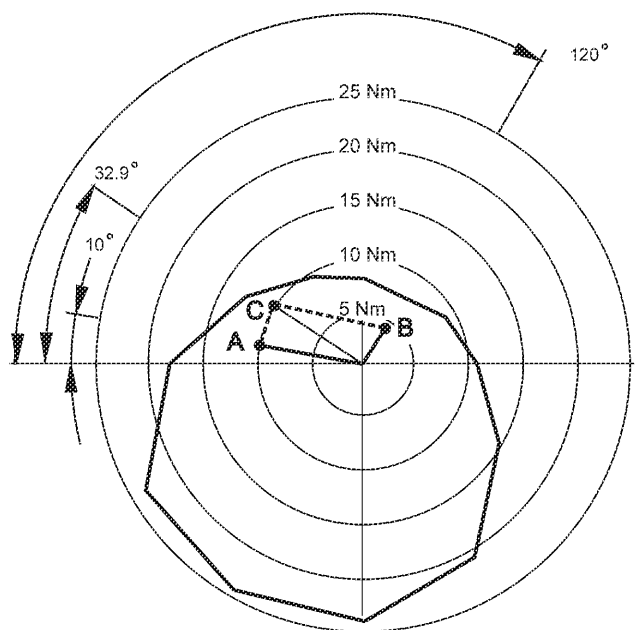

The engine is a **D1-30** and the direction of force for two auxiliaries is **A=10°** and **B=120°**.

Maximum permissible torque for auxiliary A and B depends on the vector sum of their directions of force and their torque. The combination must end up within the permissible torque range.

In this example, the torque for the auxiliary is **A=10 Nm (7.4 lbf ft)** and **B=4 Nm (3.0 lbf ft)**.

The resultant force gives a torque **C=10.1 Nm (7.4 lbf ft)** with direction of force **32.9°**. The resultant ends up within the permissible torque.

In every case:

Read off the resultant of two torques with different directions of force by drawing a parallelogram in the graph on the same principles as in the example.

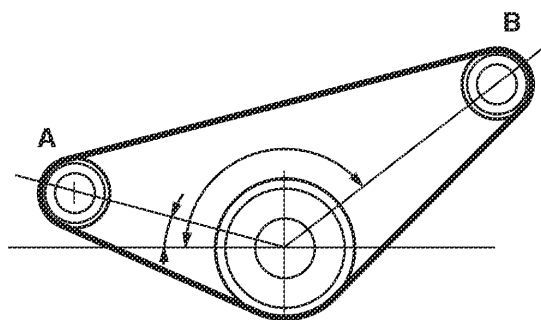

Cooling system

Seawater intake

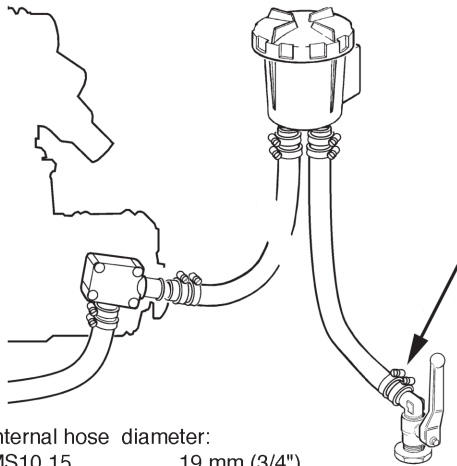

Internal hose diameter:

MS10,15	19 mm (3/4")
MS25, HS25	32 mm (1 1/4")
130S	19 mm (3/4")
150S	32 mm (1 1/4")

Always install a shut-off valve on the water intake. Two hose clamps for each connection should be used.

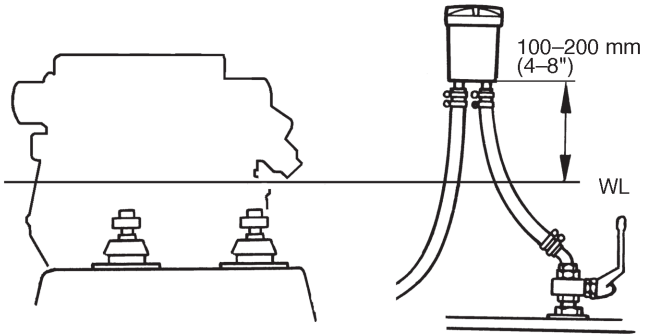

Seawater filter

The seawater filter should be installed minimum 100 mm and maximum 200 mm (4-8") above the static water line level.

NOTE! At all load conditions.

⚠ IMPORTANT! No valves or connections that could restrict water flow may be installed in the cooling system.

Seawater inlet

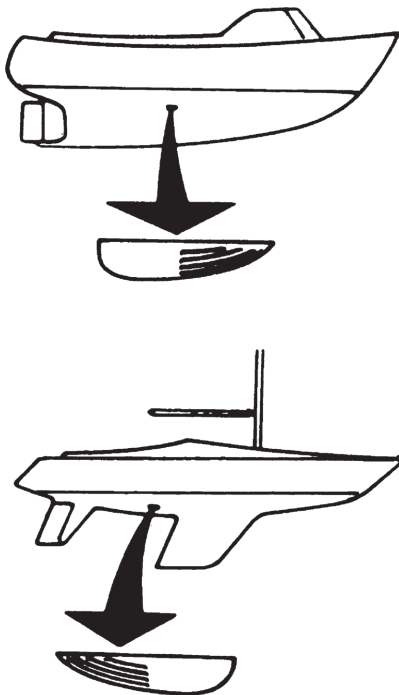

If a scoop pickup is used on a sailing boat the water intake should be facing backwards to avoid water to be pushed into the exhaust system during sailing.

Vacuum valve

⚠ IMPORTANT! Vacuum valves require service. Therefore, do not install a valve unless below criteria is fulfilled.

⚠ IMPORTANT! If the distance from static water level to exhaust outlet (A) is less than 200 mm (7.9") a vacuum valve must be installed.

Install the vacuum valve in an accessible place not less than 500 mm (19.6") above loaded water line level (B).

D1-13, D1-20, D1-30, D2-40

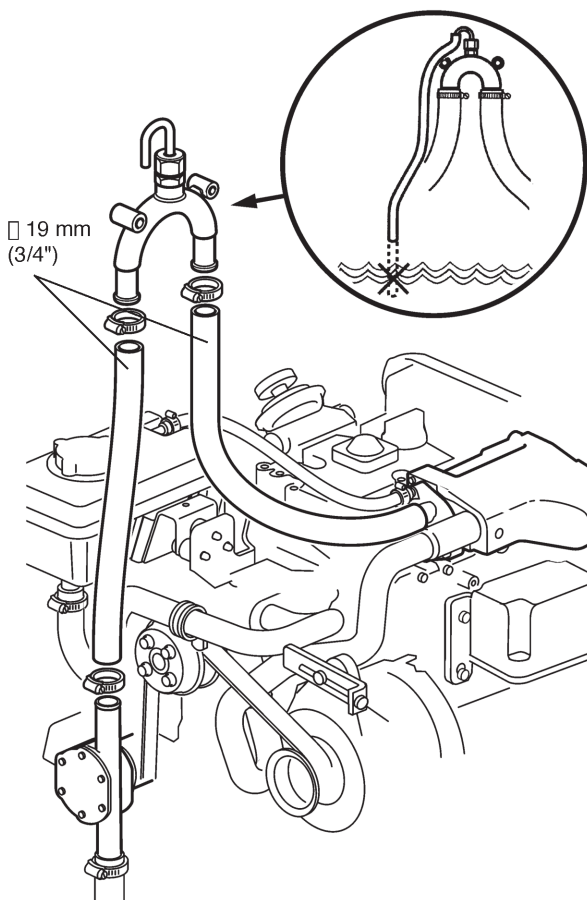

D2-55, D2-75

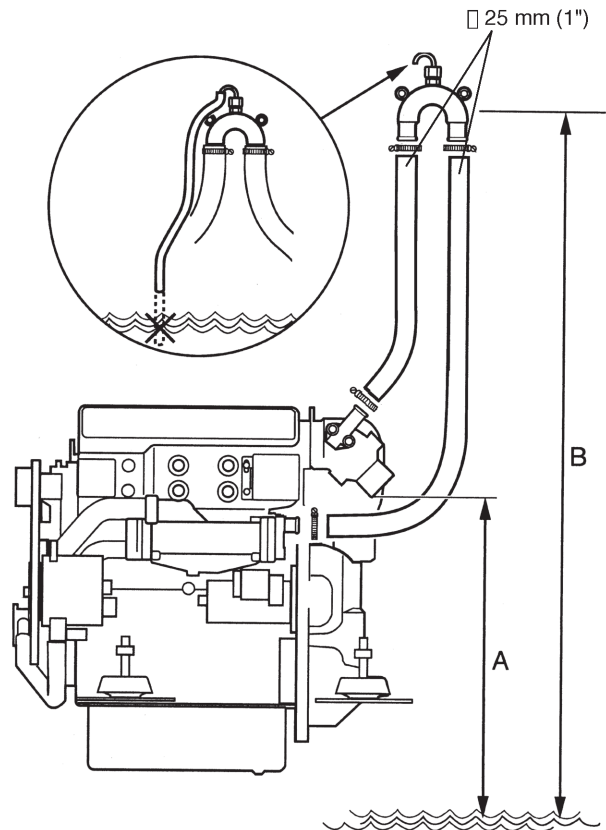

Hot water circuit

NOTE! Maximum external circuit volume:

D1-13, D1-20, D-30, D2-40	3.0 l (3.2 US qts)
D2-55, D75	1.6 l (1.7 US qts)

Larger volumes require additional expansion tank.

NOTE! All hose connections for hot water outlets are intended for a hose inner diameter of **16 mm (5/8")**.

The hoses should be bent in gentle curves and in a way which avoids them being pinched or kinked.

D1-13, D1-20, D1-30, D2-40

Outlet to hot water circuit

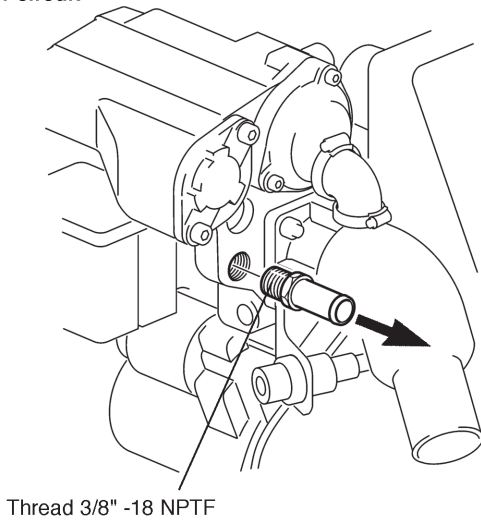

Return from hot water circuit

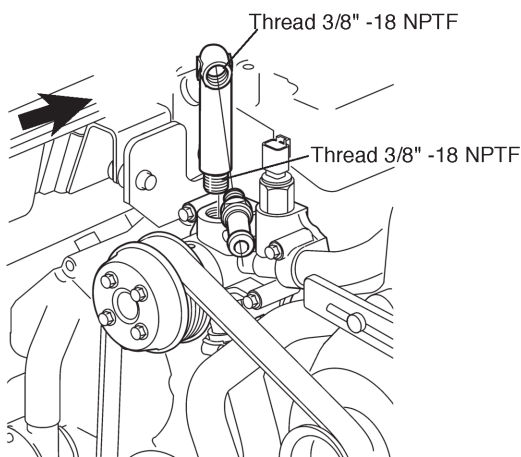

D2-55

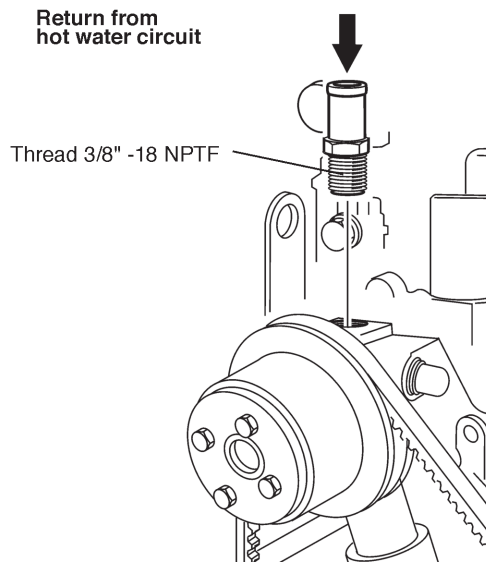
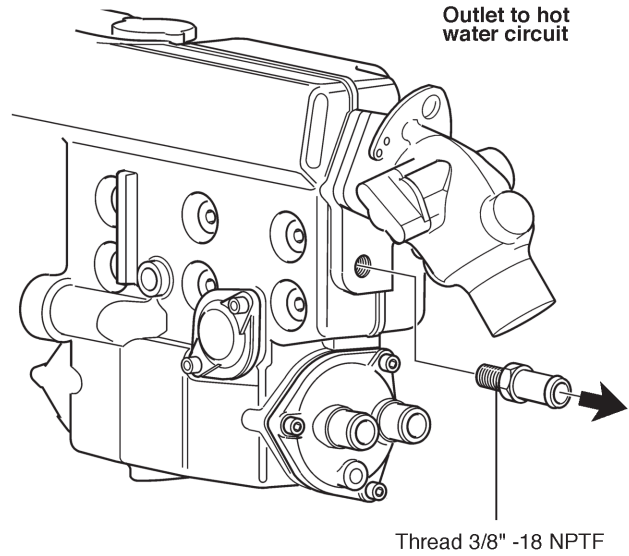

The upper edge of the hot water heater should be placed min. 50 mm (2") below the engine's expansion tank.

If expansion tank kit is mounted, the upper edge of hot water heater should not be placed higher than the "MIN" marking on the expansion tank.

The upper edge of the hot water heater should be placed min. 50 mm (2") below the engine's expansion tank.

If expansion tank kit is mounted, the upper edge of hot water heater should not be placed higher than the "MIN" marking on the expansion tank.

D2-75

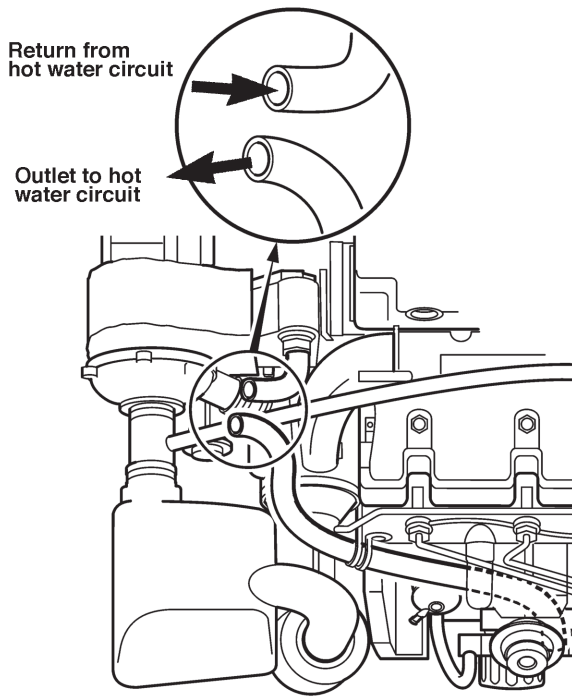

⚠ IMPORTANT! No valves or thermostats are allowed in the circuit as this may cause engine overheating.

Replace existing hose between the turbo compressor and the engine oil cooler outlet.

Install two hoses as shown in figure.

Expansion tank

D1-13, D1-20, D1-30, D2-40

The expansion tank can also be remote mounted for easy access.

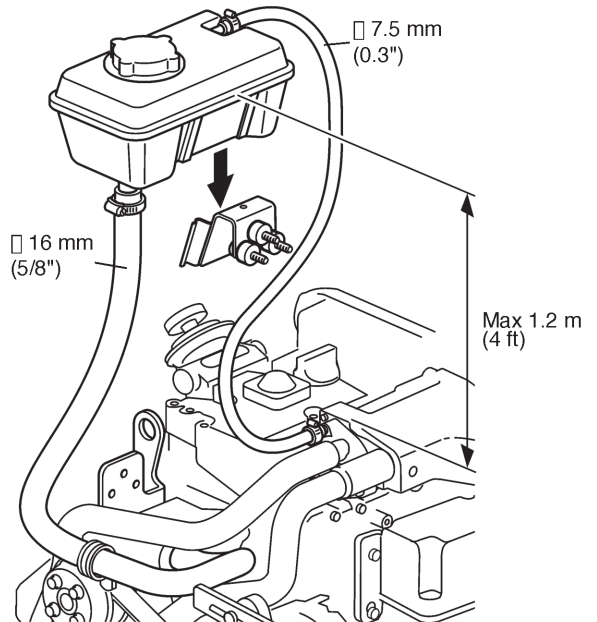

If an external circuit (hot water heater, defroster, etc) contains a larger water quantity than 3.0 liters (3.2 US qts) a larger or extra expansion tank must be installed.

If the external circuit (hot water heater, defroster, etc) is routed higher than the engine the expansion tank, the tank has to be moved according to figures. Max mounting height above engine top: **1.2 m (4 ft)**.

D2-55, D2-75

The loose standard expansion tank must be bulk-head mounted.

If an external circuit (hot water heater, defroster, etc)

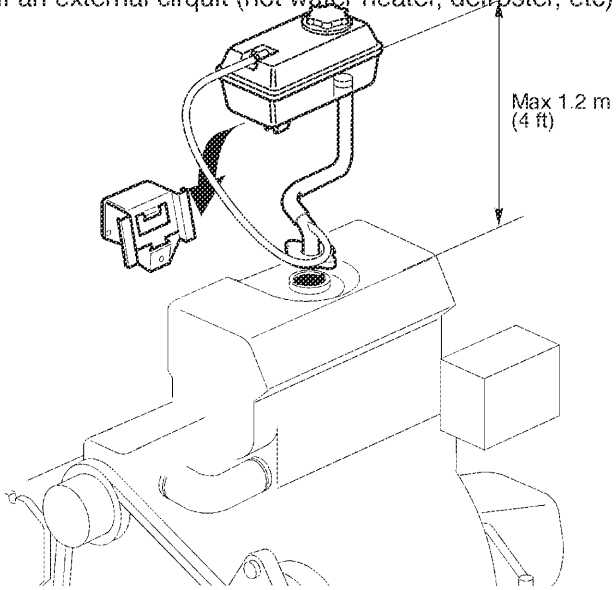

contains a larger water quantity than 1.6 liters (1.7 US qts) or the circuit is routed higher than the engine a larger or extra expansion tank must be installed.

If the external circuit (hot water heater, defroster, etc) is routed higher than the engine the expansion tank, the tank has to be moved according to figures.

Max mounting height above engine top: **1.2 m (4 ft)**.

Exhaust system

Routing of exhaust hose between silencer and exhaust bend

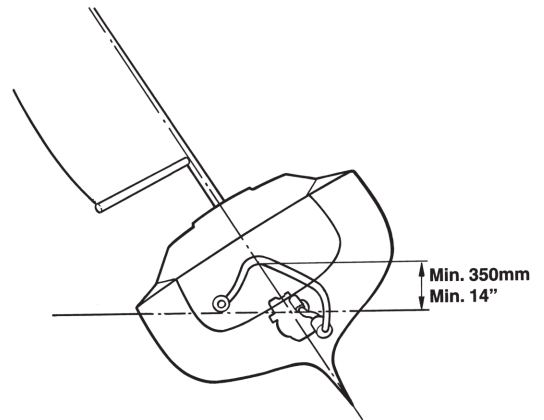
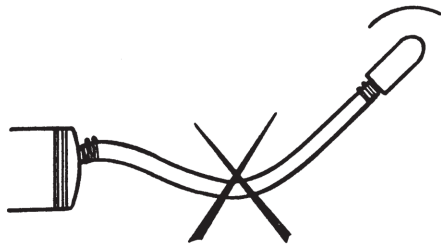
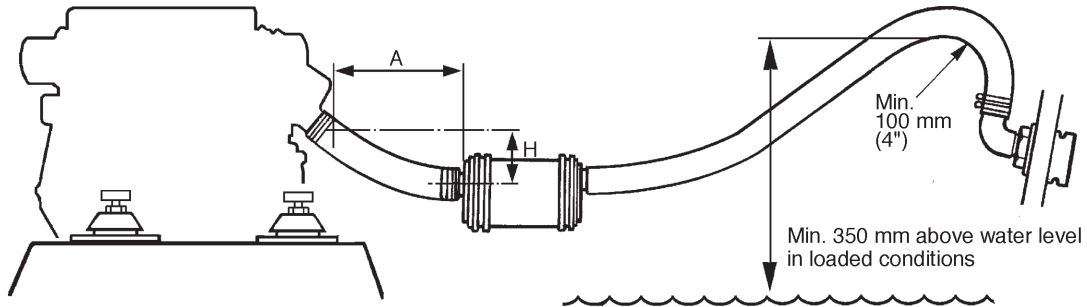

⚠ IMPORTANT! Residual water must flow to silencer or overboard when the engine is shut off.

Highest position of silencer in relation to exhaust hose length, all engines

mm (inch)

A	H
300 (11.8)	110 (4.3)
400 (15.7)	120 (4.7)
600 (23.6)	150 (6.0)
1300 (51.2)*	180 (7.1)

*) Support needed to avoid water to stay in hose before silencer.

⚠ IMPORTANT! If measurement H cannot be met, an exhaust riser has to be installed.

Exhaust riser D1-13, D1-20, D1-30, D2-40

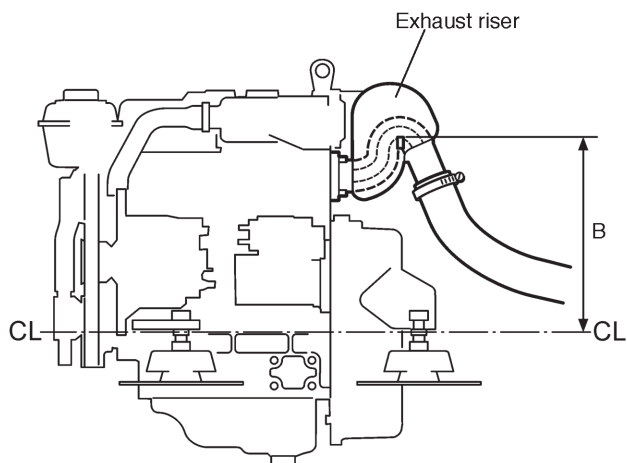

Standard installation

Engine	B measurement, mm (")
D1-13	197 (7.75)
D1-20	197 (7.75)
D1-30	222 (8.75)
D2-40	222 (8.75)

Exhaust riser installation

Engine	B measurement, mm (")
D1-13	288 (11.3)
D1-20	288 (11.3)
D1-30	323 (12.7)
D2-40	323 (12.7)

The riser increases the overall engine installation height by **12 mm (0.5")**.

Exhaust hose dimensions

Engine	Hose inner diameter mm (")
D1-series	45 mm (1 3/4)
D2-40	45 mm (1 3/4)
D2-55	57 mm (2 1/4)
D2-75	90 mm (3 1/2)

Exhaust back pressure measurements, kPa, (psi / mm Wc)

Engine	Back pressure	
	Minimum	Maximum
D1-series	—	20 (2.9/2040)
D2-40	—	20 (2.9/2040)
D2-55	15 (2.2/1530)	20 (2.9/2040)
D2-75	15 (2.2/1530)	20 (2.9/2040)

Engine room ventilation

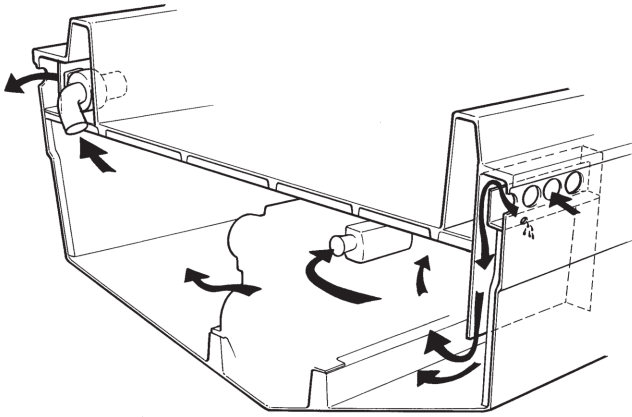

Two main conditions must be met:

1. The engine must receive enough air (oxygen) for combustion of the fuel.
2. The engine room must be ventilated, so that the temperature can be kept down to an acceptable level.

Ventilation is also important to keep the engine's electrical equipment and fuel system at a low temperature, and to ensure general cooling of the engine.

NOTE! All valid safety regulations and legal requirements for each country must be followed. Each classification society has its own regulations that must be followed when required.

The temperature of the inlet air at the air filters must not be higher than +25°C (77°F) for full power output. During sea trials the air temperature in the air filter should not exceed **20°C (36° F)** above ambient temperature.

The temperature of the engine itself is rather high in some places. Certain separate electric components, such as charging regulators and relays, should therefore be fitted on bulkheads or elsewhere where the temperature is relatively low.

The **maximum temperature** for areas where electric components are fitted is **70°C (158°F)**. The starter motor and alternator however, have their given locations.

NOTE! The total intake area can be calculated by using the formula:

$$\text{Total intake area} = \text{Engine air consumption} + \text{Engine room ventilation}$$

Area in cm²

Engine air consumption

The engine consumes a certain amount of air in the combustion process. This requires a minimum internal area in the air supply ducting.

The area can be calculated by using the formula:

$$A = 1.9 \times \text{engine power output}$$

A = Area in cm²

Engine output in kW

The value applies for non-restricted intake and up to 1 m (3.3 ft) duct length with only one 90 degree bend. The bending radius should be at least twice the diameter.

If longer ducts or more bends are used, the area should be corrected by multiplying by a coefficient from **Table 1** below.

Number of bends	Duct length, m (ft)				
	1 (3.3)	2 (6.6)	3 (9.8)	4 (13.1)	5 (16.4)
1	1	1.04	1.09	1.13	1.20
2	1.39	1.41	1.43	1.45	1.49
3	—	1.70	1.72	1.74	1.78

Table 1.

Engine room ventilation

A great deal of the radiant heat must be transported out of the engine room to keep the engine room temperature down to the permitted values, in other words the heat must be ventilated away .

The same dimension must be chosen for the inlet and outlet ducts to achieve low flow speeds and low noise levels.

The area of the inlet/outlet air supply is calculated using the formula:

$$\text{Inlet air} = 1.65 \times \text{engine power output}$$

$$\text{Outlet air} = 1.65 \times \text{engine power output}$$

Areas in cm²
 Engine power output in kW.

These values must be corrected according to **Table 1** with regard to bends and duct length.

The ambient air temperature (outdoor air temperature) is assumed to be +30°C (86°F). Correction factors as per **Table 2** shall be used where applicable.

Ambient air temperature °C (°F)	Correction factor
+20 (68)	0.7
+30 (86)	1.0
+40 (104)	1.4

Table 2.

Fan selection

The fan must be dimensioned according to air flow volumes as follows:

$$\text{Air flow} = 0.07 \times \text{engine power output}$$

Air flow volume in m³ /min
 Engine power output in kW.

The total pressure increase across the fan should be 10 mm (0.39") water column (100 pa).

These two values, flow and total pressure increase, are sufficient for the selection of a fan. If the fan is fitted directly to the bulkhead, i. e. without a connection pipe, the value of the total pressure increase can be reduced to 7 mm (0.28") water column (70 pa). This means that a somewhat smaller fan can be used.

Soundproofing

The drive package must be installed in such a way as to minimize noise and vibration. The noise that occurs is airborne noise and structural noise (vibration).

Structural noise

Vibration from the engine is transmitted via the engine mountings and the engine bed to the hull. Other routes are via the transmission and propeller systems, exhaust pipe, coolant pipes, fuel pipes, electrical cables and control cables.

Pressure pulses from the propeller are transmitted through the water and into the hull. Pulsating thrust from the propeller enters the hull via support blocks, bearings and seals.

Airborne noise

This section refers to airborne noise from the engine bay. The most important measure to lower airborne noise from the engine room is to seal the room properly. Further improvements in noise level reduction can be achieved by sound insulation material and by designing sound traps for the air inlets.

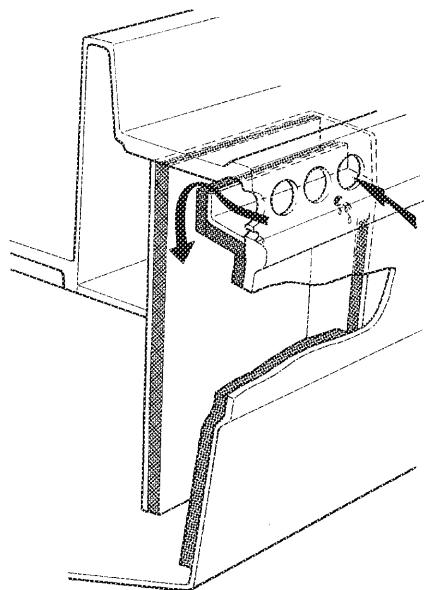

The engine installation should be soundproofed in order to obtain a noise level that is as low as possible. Build the engine compartment with sound traps. Various types of sound traps can be selected. The figure shows a type that is also provided with drainage.

Furthermore, due consideration must be given to the thickness of the insulation material.

The greatest possible care must be given to the task of screening the sound source as well as possible. Screen all the way down to the hull but leave a small distance to prevent bilgewater from penetrating the insulation material.

Cracks, openings etc. must be carefully sealed off with insulation material. In cases where the engine is installed under the floor, line all bulkheads and floorboards.

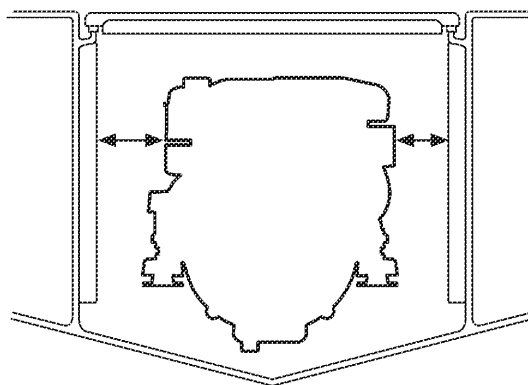
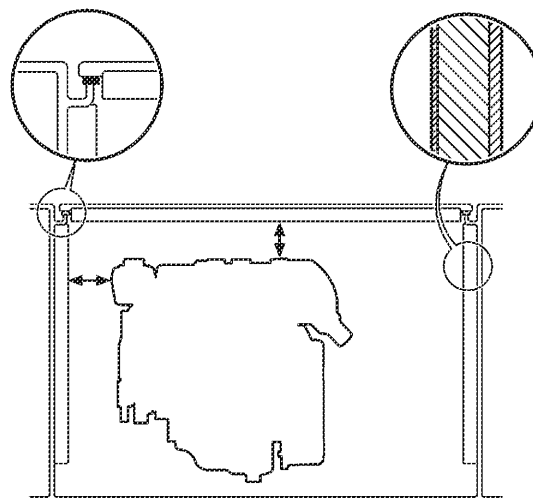

Prior to installing the insulation material, make sure that there is sufficient room for checking, service and repair and for engine movements during operation.

Also make sure that all hatches are properly sealed.

Make sure the necessary room is available for service and repair. Also make sure that all hatches are properly sealed.

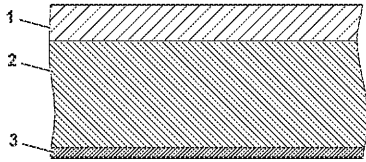

Insulation material installed on wood (plywood):

1. Wood (plywood)
2. Flame-proof absorption sheeting.
3. Flame-proof, reflecting soundproofing foil.

Above you can see an example of the construction of an insulation material. This type of insulation material is glued to the frame.

NOTE! The insulation sheeting faces differently, owing to the type of the material in the frame, i.e. GRP or wood.

Insulation material, being applied on wood (plywood):

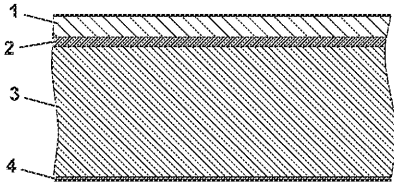

Insulation material installed on GRP:

1. GRP
2. Iron-PVC, thickness 2.5 mm (0.1")
3. Flame-proof absorption sheeting
4. Flame-proof, reflecting soundproofing foil

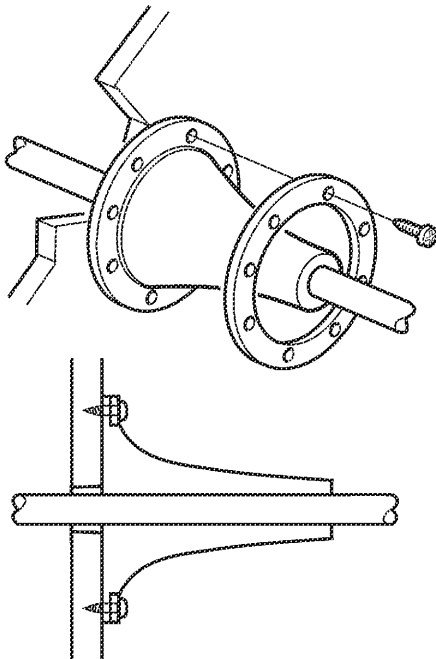

Shift cables, throttle cables and electrical wires coming through bulkheads can preferably be drawn through a tube or a grommet, sealing off properly. At the same time the cables are protected against wear.

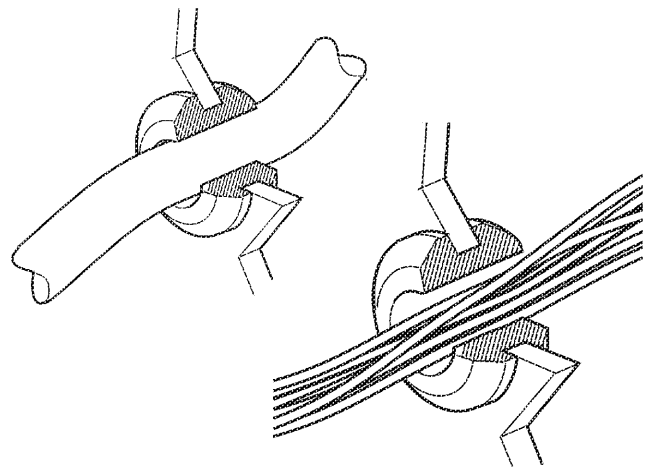

Fuel hoses going through a bulkhead should be protected by a grommet where they pass through the bulkhead. The grommet seals off and protects the hose against sharp edges, which might cause leakage.

Other cables, electrical wires, battery leads etc can be drawn through a rubber hose or through a special PVC-tube (electrical conduit), built onto the GRP bulkhead of GRP. Any gaps between the tubing and the wires can be sealed off with some kind of insulation material or sealing compound.

Fuel system

Piping

All fuel lines should be installed and properly clamped near the bottom of the boat to avoid heat absorption. The air temperature is lower at the bottom of the engine room.

Rubber hoses

Clamp the fuel line. Distance between clamps approx. 300 mm (12").

Make sure the hose cannot be damaged by sharp edges.

NOTE! Legal requirements may demand fuel shut-off valve on return line.

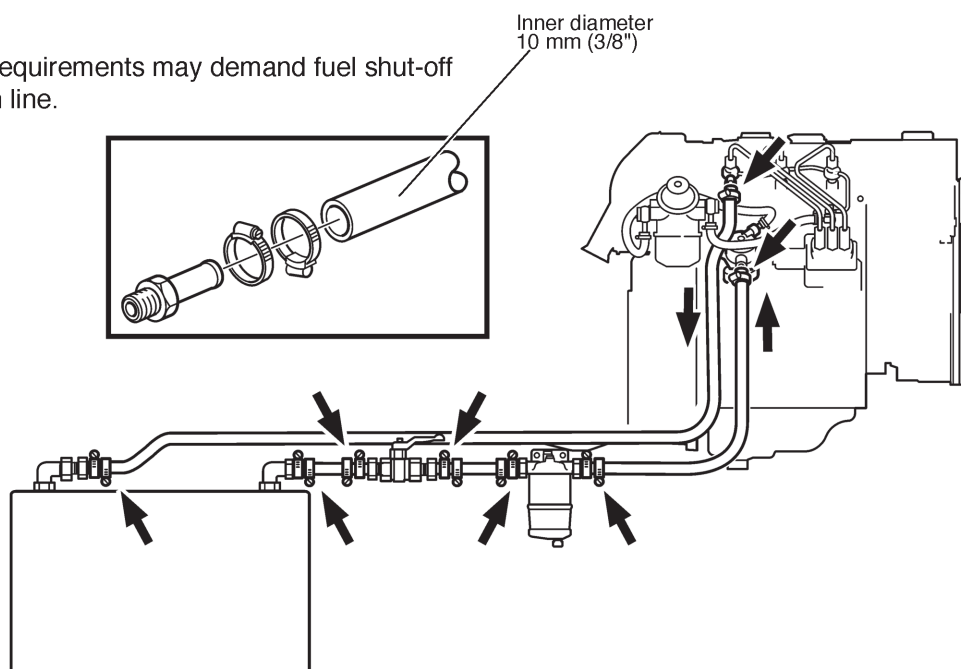

Inner diameter

Required minimum inner diameter for
 feed line hose: **10 mm (3/8")**.
 return hose: **10 mm (3/8")**.

NOTE! Only use approved flexible hose.

Connections

Min. inner diameter: **7.0 mm (0.28")**
 Male thread : **1/4" NPTF**
 Volvo Penta part no.: **3825000**

Steel and copper piping

Clamp the fuel line. Distance between clamps approx. 300 mm (12").

When steel and copper pipes are used there must be a flexible connection (hose) between the pipe and the engine.

The figure shows a transition from flexible fuel hoses (1) to steel or copper pipes (2).

Outer diameter

Required minimum outer diameter for
 feed line pipe: **10 mm (3/8")**
 alt. **12 mm (1/2")**.
 return pipe: **10 mm (3/8")**

NOTE! Legal requirements may demand fuel shut-off valve on return line.

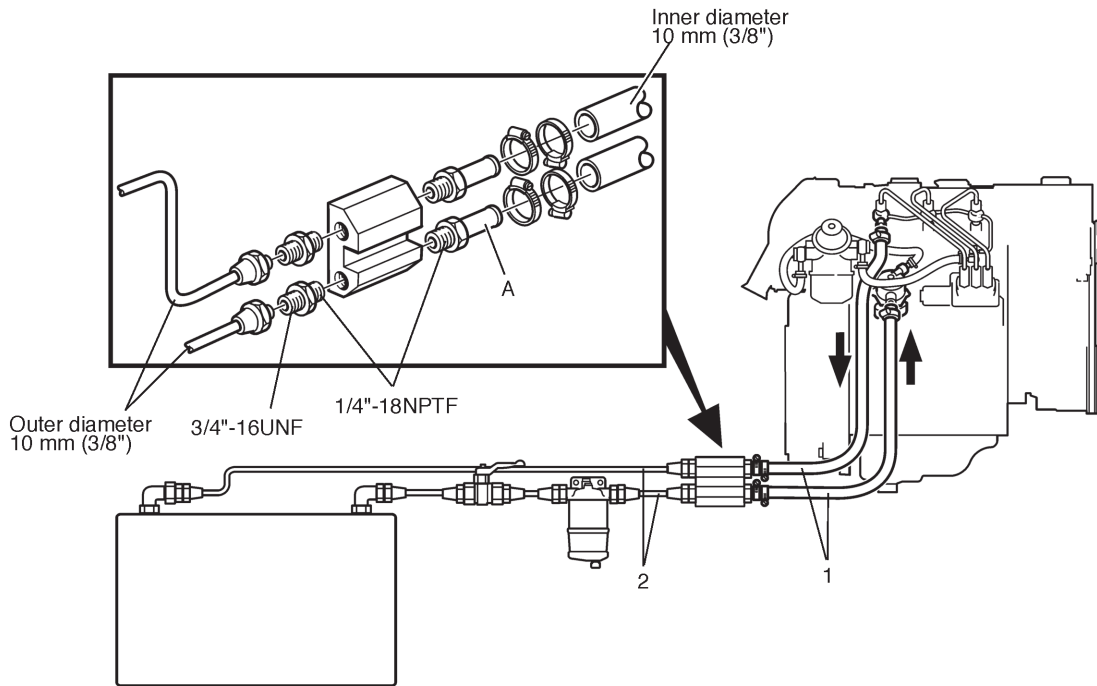

Connections

Min. inner diameter: **7.0 mm (0.28")**

Male thread : **1/4" NPTF**

Volvo Penta part no.: **3825000**

Fuel pre-filter

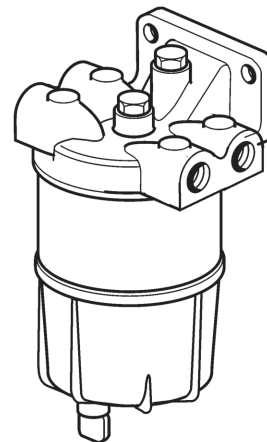

Use a fuel pre-filter of correct size to avoid excessive resistance across the filter. The recommended filtration is 10 micron (10µ) .

NOTE! Fuel pre-filters with a glass bowl may not be installed in boats intended to be CE-marked.

Electrical system

MDI

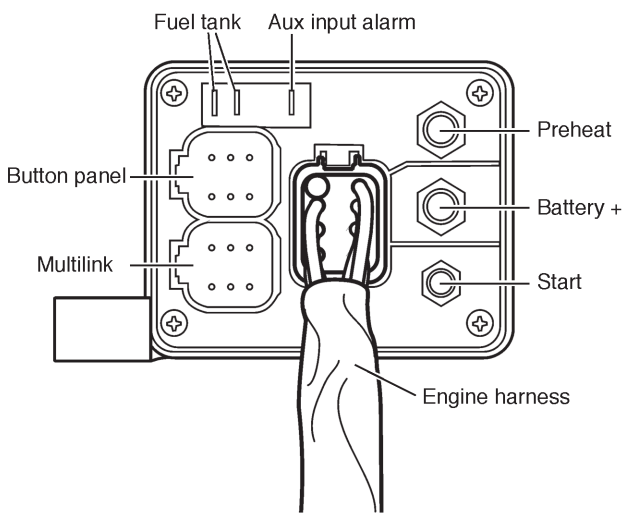
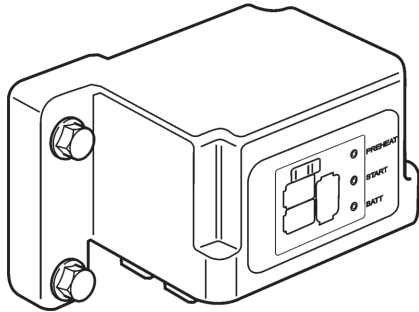

The MDI is located at the engine and is connected to a number of nearby components, such as sensors, control panel and instruments.

A data link (CAN bus) links the MDI to the tachometer/display and other optional equipment such as NMEA2000 interface and multisensor.

⚠ IMPORTANT! Note connection of engine harness to MDI.

Control panel

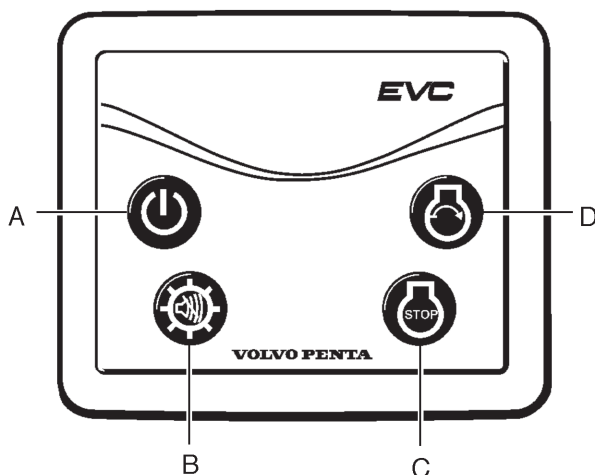

A. On/Off button

Press this button to engage or turn off the system.

NOTE! The control panel must not be turned off while the engine is running.

B. Multifunction button

- Alarm acknowledgement
- Dimmer (background lighting)
- Contrast (tachometer LCD)

C. Stop button

The engine stop running when this button is pressed.

D. Start button

When this button is pressed the glow function is activated and the starter is engaged.

Minimum instrumentation

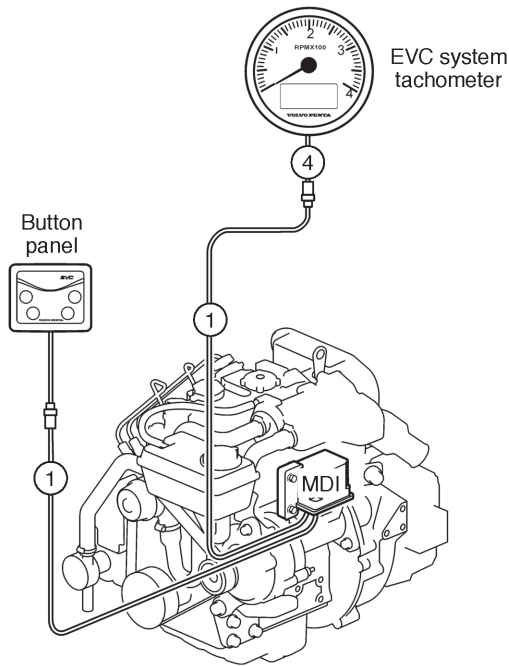

Optional instrumentation

⚠ IMPORTANT! The MDI system allows maximum one EVC system tachometer and/or one EVC system display in the system.

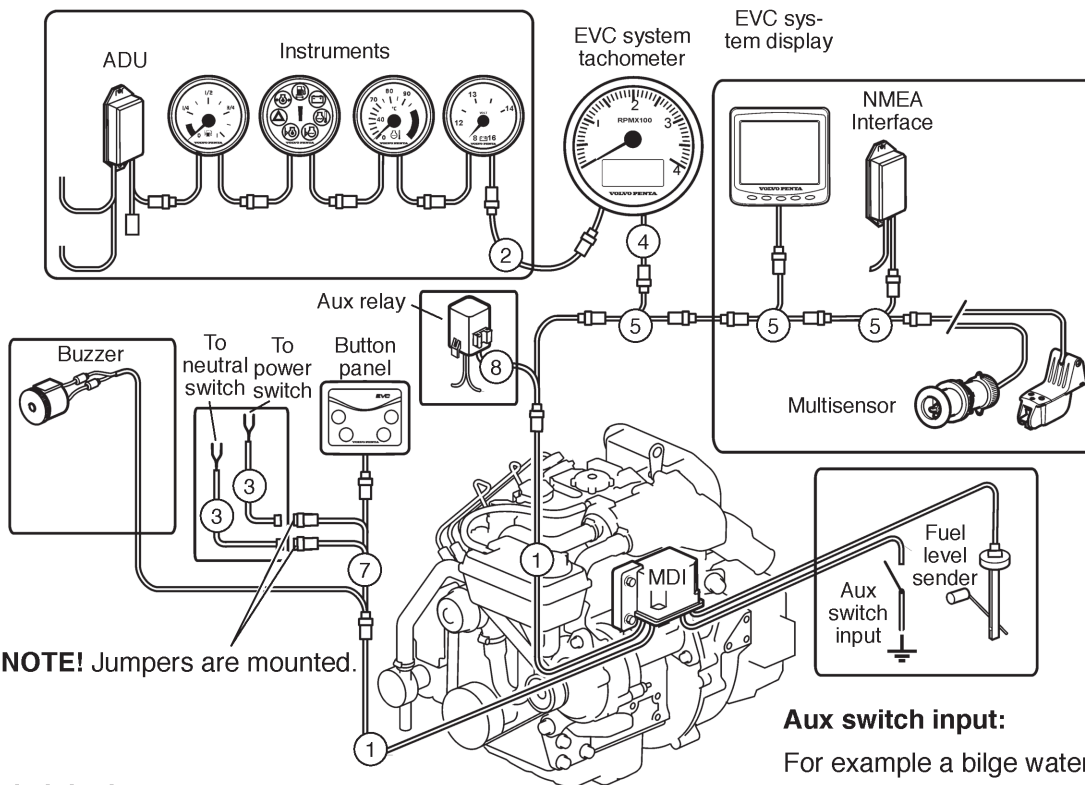

Aux switch input:

For example a bilge water level switch

Fuel level sender resistance:

3 - 180 ohms, 3 ohm = empty tank

Switch logics

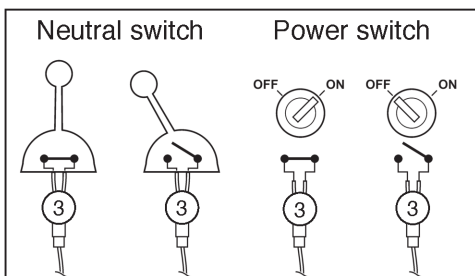

Secondary helm station

⚠ IMPORTANT! The MDI system allows maximum one EVC system tachometer and/or one EVC system display in the system.

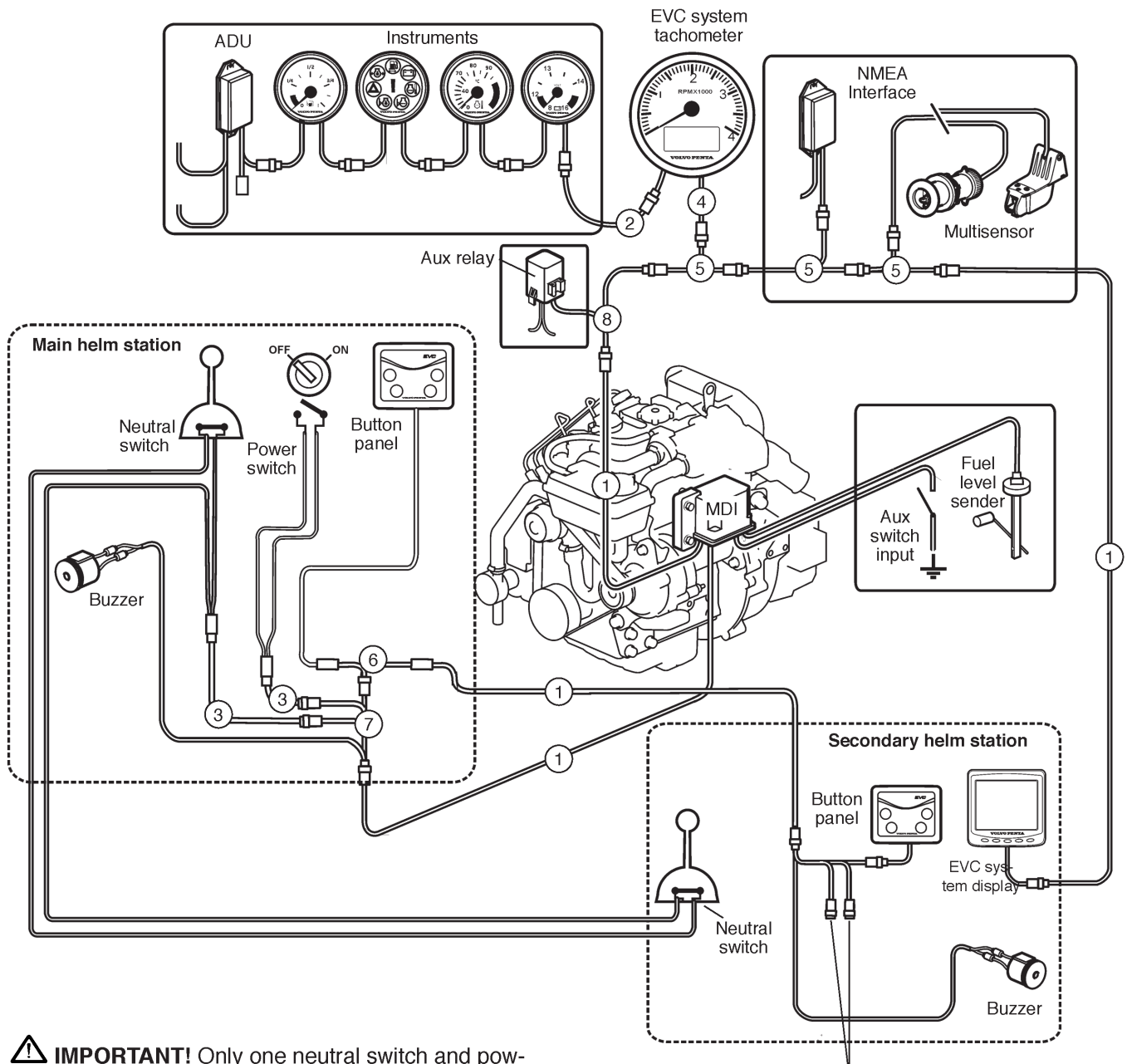

⚠ IMPORTANT! Only one neutral switch and power switch input shall be installed to the MDI. The neutral switch function shall be routed in serial to both helm stations/controls for full functionality.

⚠ IMPORTANT! The cable for neutral switch, power switch and buzzer shall be interconnected between the Y-connector and engine, at main helm station.

NOTE! Jumpers are mounted. Neutral switch and power switch shall not be used. Only buzzer on secondary helm station.

Cables and cable harnesses

Pos. in figure	m	ft
1. Extension cable, 6-pin	1.5	5
	3.0	10
	5.0	16
	7.0	23
	9.0	30
	11.0	36
2. Extension cable, 3-pin For Easylink instruments (gauges)	1.5	5
	3.0	10
3. Connection cable, 2-pin	10.0	32
4. Tachometer cable, 6-pin For tachometer and multilink	1.5	5
5. Y-split, multilink, 6-pin		
6. Y-connector, 6-pin (P/N 874760)		
7. Cable harness For neutral switch, power switch and buzzer		
8. Auxiliary relay cable		

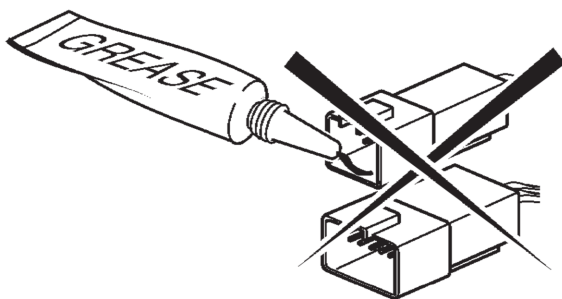

⚠ IMPORTANT! Never use any kind of grease in the EVC connectors.

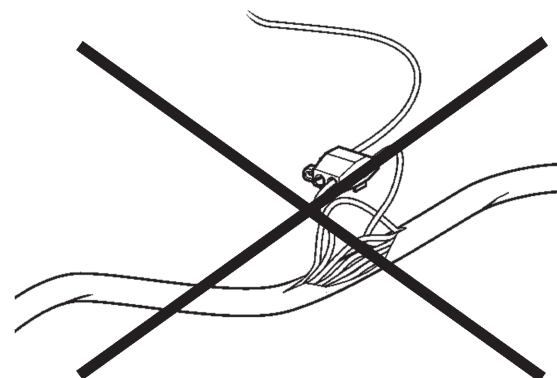

⚠ IMPORTANT! Never cut or modify the Volvo Penta EVC cable harnesses.

Connection of battery cables

With charge distributor

NOTE! Remove the 25 mm² cable between alternator and starter when a charge distributor is installed.

Connection of diod/sensor cable system to standard alternator, principle drawing

1. Sensor conductor (yellow, 1.5 mm², 16 AWG)
2. Charge distributor (accessory)
3. Alternator, 115 A
4. Fuse panel (accessory)
5. Starter
6. Main switch
7. Accessory batteries (accessory)
8. Start battery (engine)

Another battery may be installed in parallel (+ to + and - to -) to obtain more battery capacity for accessories.

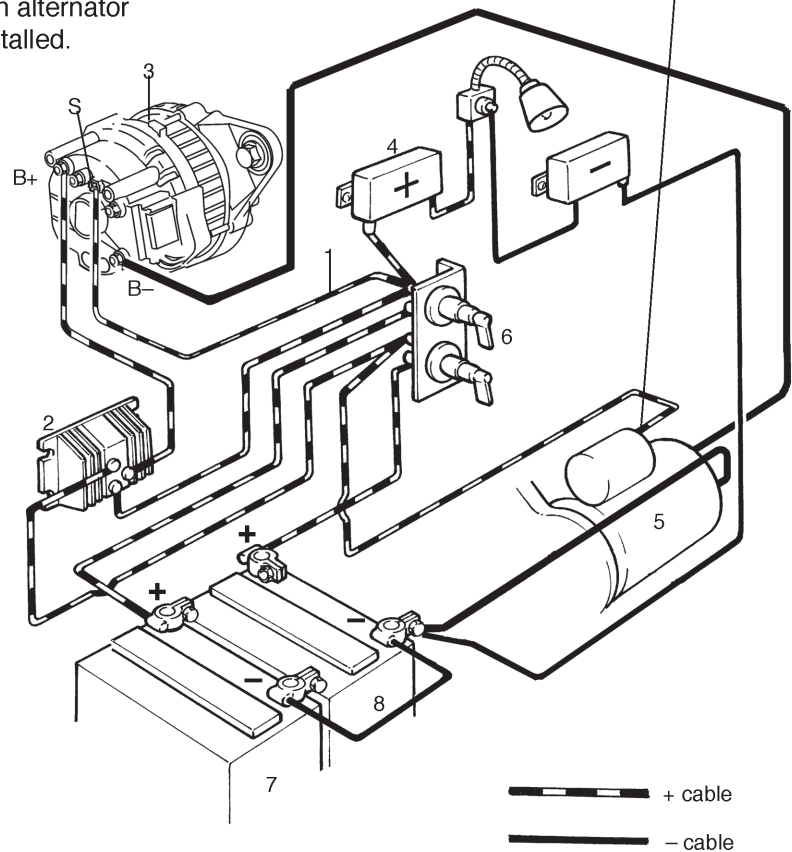

Without charge distributor

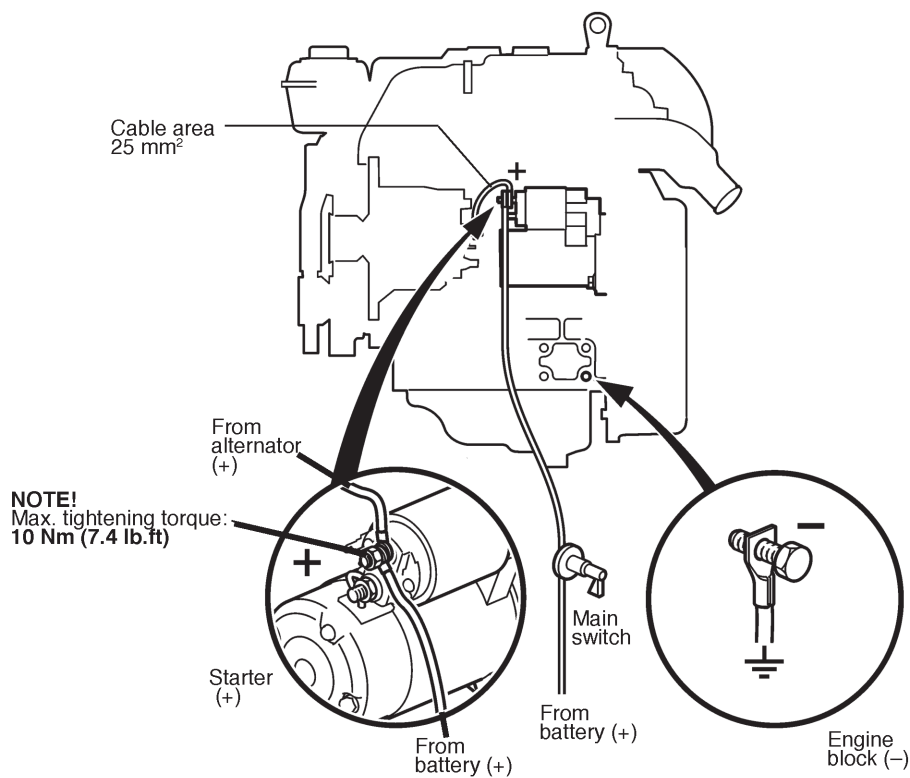

Total cable length and cable area, battery to starter

For cables that carry starting current, for systems with and without charge distributor.

Cable length in meter (ft)	-1.3 (-4.2)	1.3-1.8 (4.2-5.9)	1.8-2.6 (5.9-8.5)	2.6-3.7 (8.5-12.1)	3.7-4.8 (12.1-15.7)
Cable area in mm ² (min)					
Engine D1	25	35	50	70	95
D2	35	35	50	70	95

Total power cable length and cable area, alternator-battery

For cables that carry charging current, for systems with charge distributor.

Cable length in meter (ft)	-2.5 (8.2)	2.5-3.5 (8.2-11.5)	3.5-5.0 (11.5-16.4)	5.0-7.0 (16.4-23.0)
Cable area in mm ² (min)				
Engine D1, D2	25	35	50	70

Main switch requirements

Normal voltage	Nominal capacity			Working temp. 5.5 min.	Max.	Standard degree	Protection
	Contin-uous	During	During 5 sec.				
≤48V	150A	1000A	450A	+ 85°C +185°F	SAE J1171 Marine	IP 66	

**Relation between mm²
(sq in) and AWG**

AWG in	mm ² (std.)	sq.
18	0.75	0.029
16	1.5	0.044
14	2.5	0.098
12	2.5	0.098
10	6	0.236
8	10	0.393
6	10	0.393
5	16	0.629
4	25	0.984
3	25	0.984
2	35	1.378
1/0	50	1.969

Recommended start battery capacity

Engine	Ah	CCA SAE standard
D1	70	540
D2	88	700

CCA = Cold Cranking Amp.**AWG = American Wire Gauge**

Controls

Connecting the speed control cable

⚠ IMPORTANT!
To be counter locked.

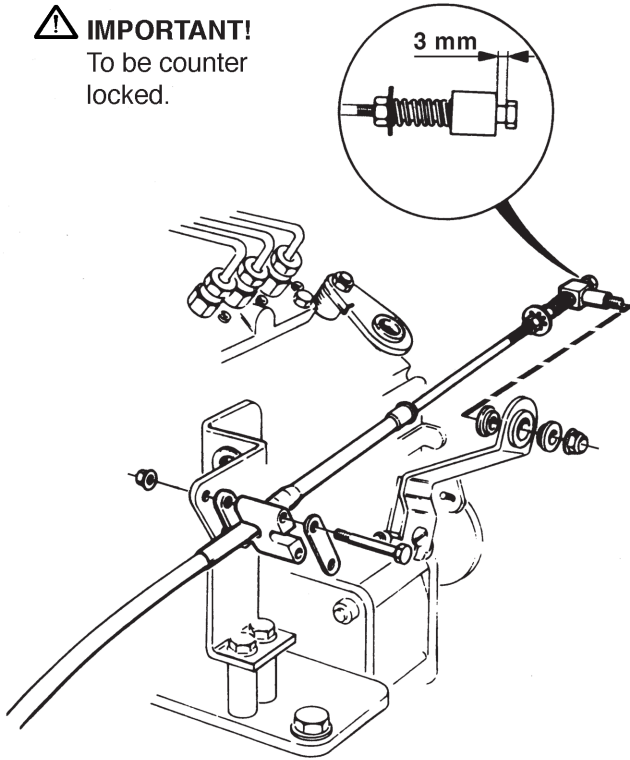

Connecting the gear shift cable

⚠ IMPORTANT! The gear shift cable routing is very important for control functionality. The shift cable must attach to the reverse gear lever in a straight and unstrained way.

Sail boat drive 130S/SR, 150S/SR

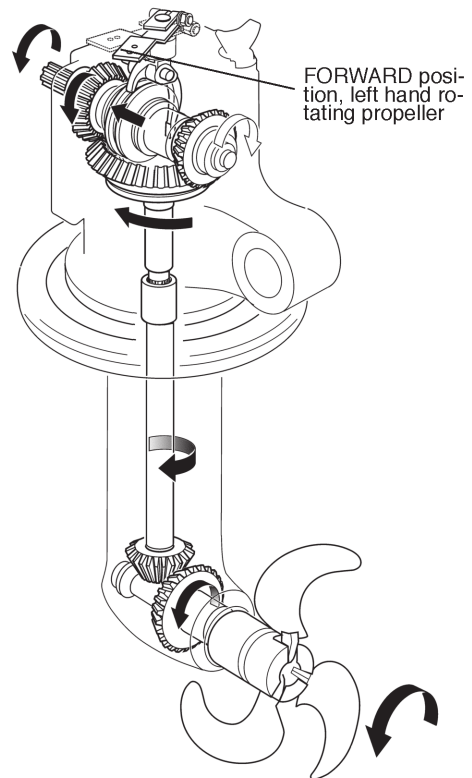

Left-hand propeller

Standard recommendation is propeller with left hand rotation for forward.

Reverse gear MS10, MS15, MS25

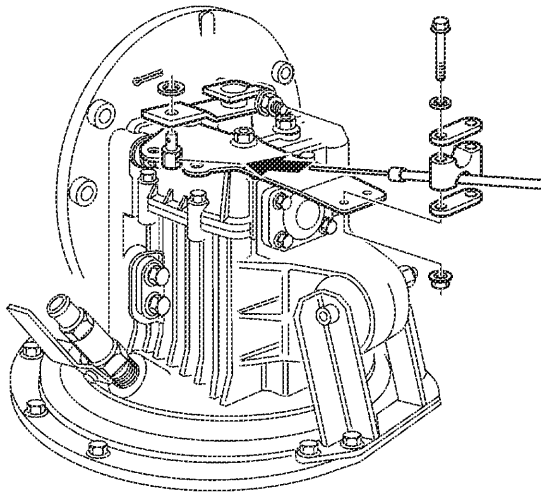

From astern

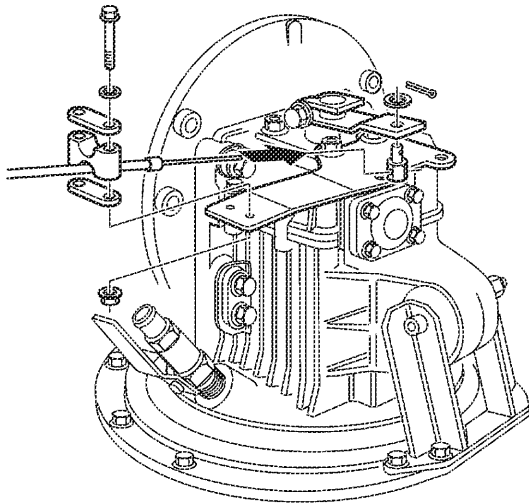

From port side

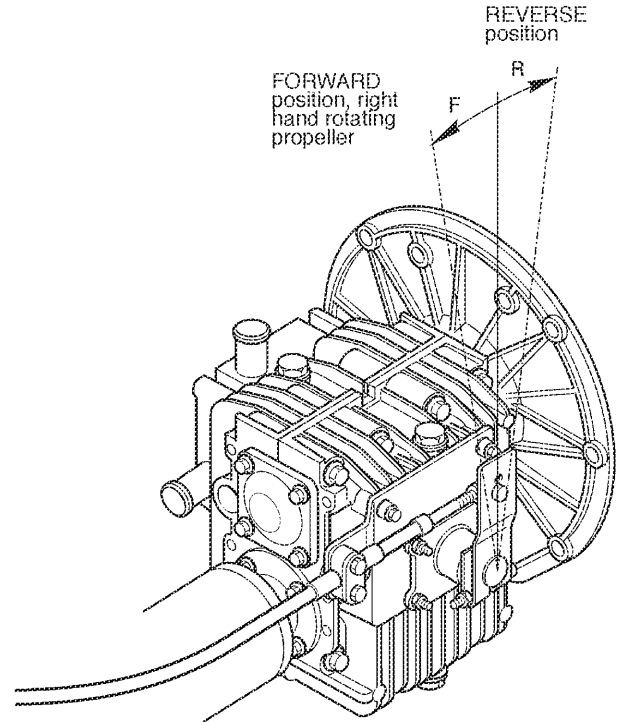

Right-hand propeller

Standard recommendation is propeller with right hand rotation for forward.

The bracket may be turned 90° for cable installation from above.

The bracket can be mounted for cable installation from astern and from port side.

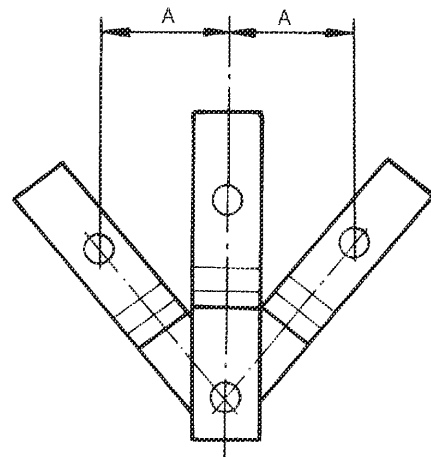

A = 25–30 mm (1.0–1.2")

Reverse gear HS25

Alternative connection 1

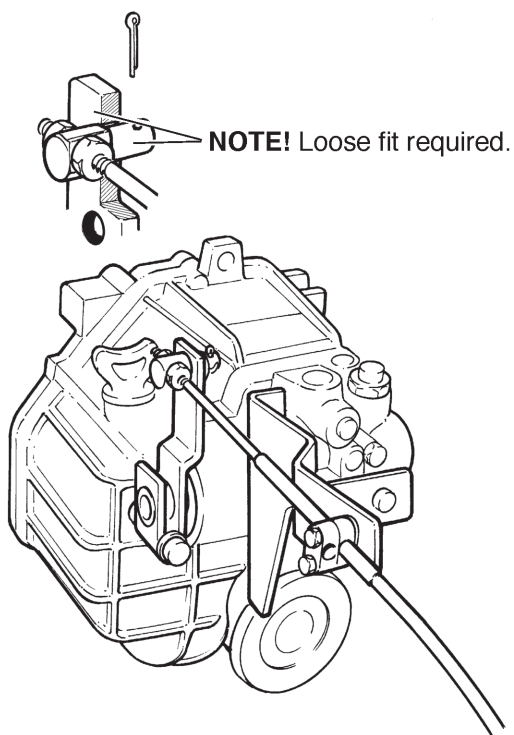

Alternative connection 2

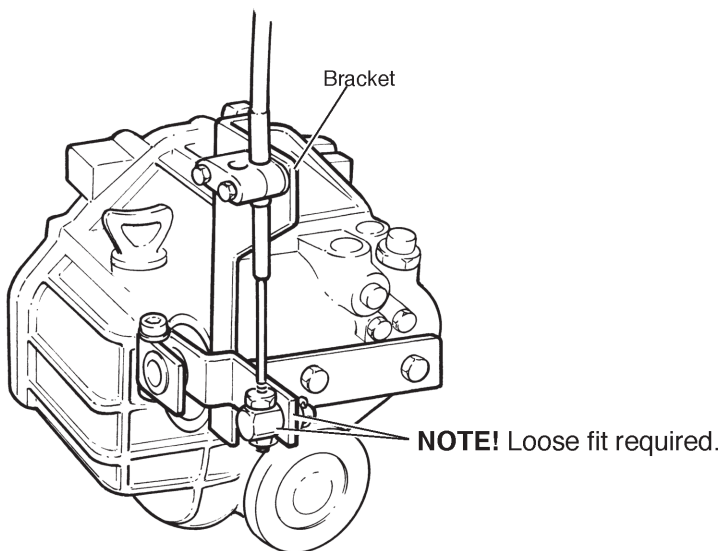

In order to install the cable according to alternative 2, a bracket is available as an accessory.

Reverse gear HS25

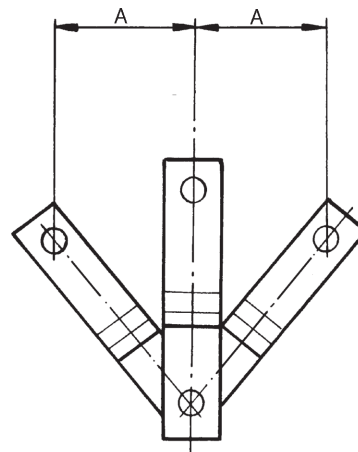

A = 30–35 mm (1.2–1.4")

Reverse gear HS25 with trolling valve

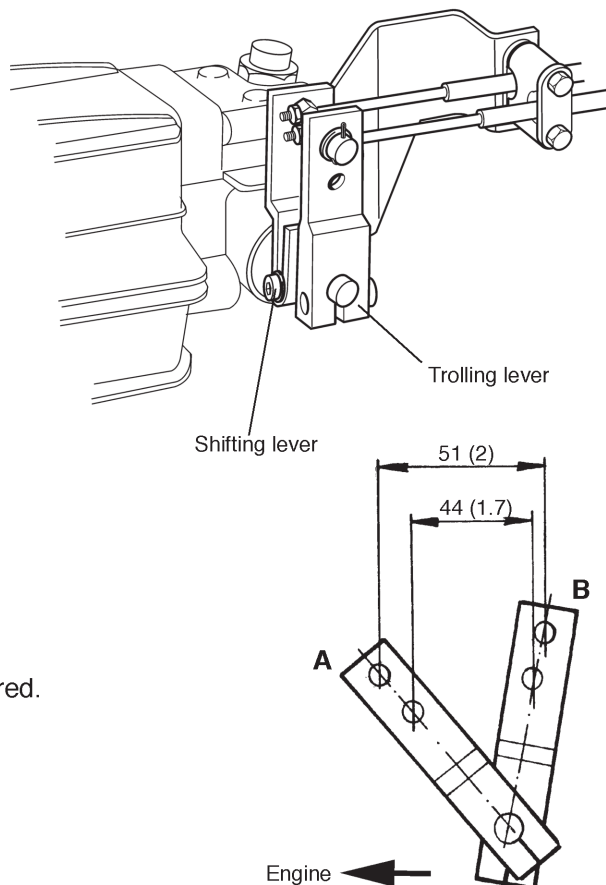

Position **A**: Maximum slipping
 Position **B**: Trolling function off

Lever travel for the outer pivot point from position B–A: 51 mm (2")

Lever travel for the inner pivot point from position B–A: 44 mm (1.7")

S-drive installation

Preparations step 1–8

1

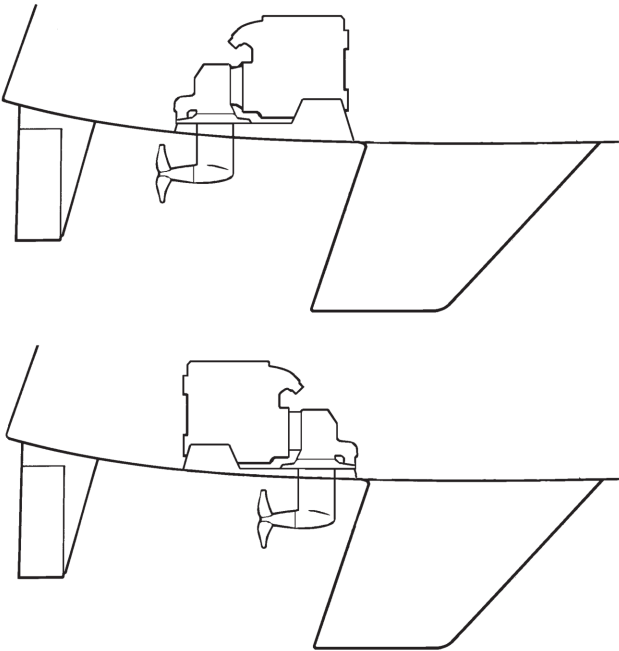

Engine mounting

The engine may be installed with the flywheel facing forward or backwards.

2

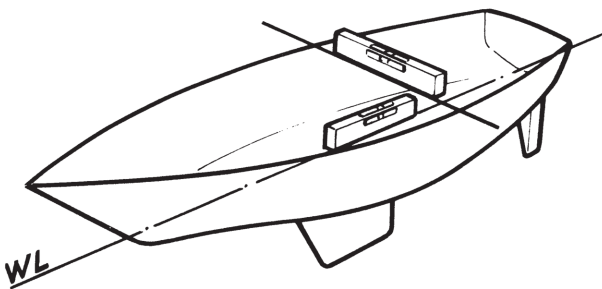

Adjust the boat so the expected waterline is horizontal both length – and sidewise

3

Alternative 1

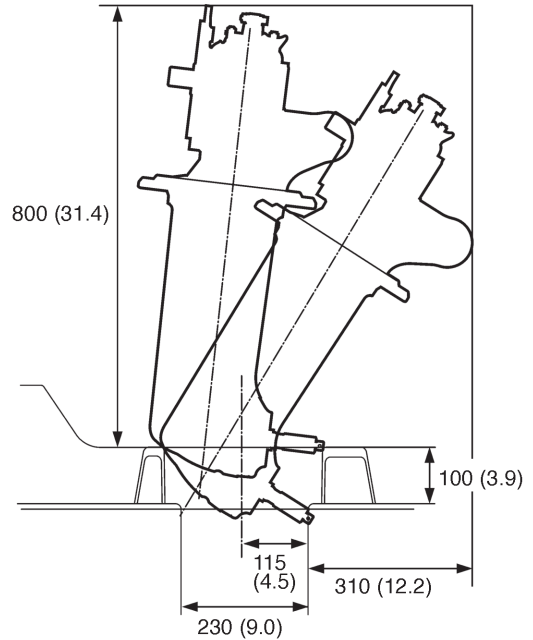

Alternative 2

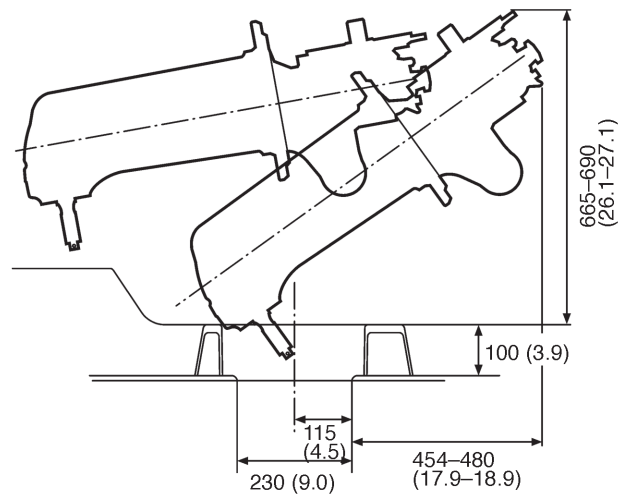

Necessary space for drive to be installed/taken out.

NOTE! Make sure it is enough space to mount and dismount the drive for future maintenance and repair.

4

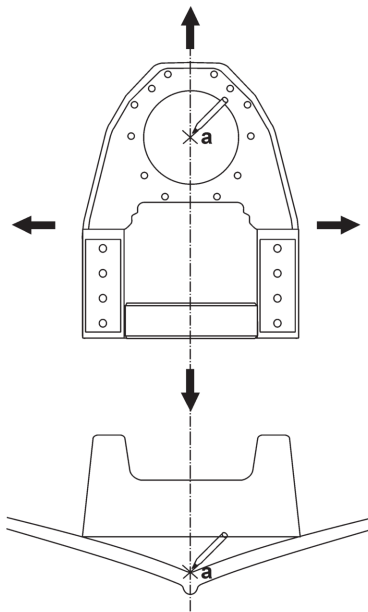

Position point "a" in hull

Make a line along the center line of the boat.
 Make sure there is space for bonding the engine bed to the hull.

5

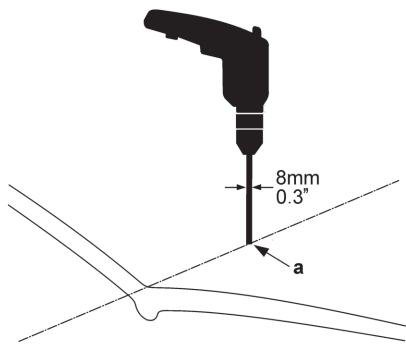

Drill a hole in position (a), diameter 8 mm (0.3")

6

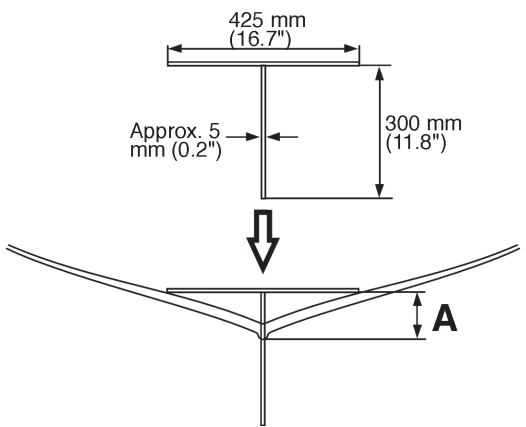

Measure distance (A)

In order to cut the bed correctly, measurement A must be taken.

7

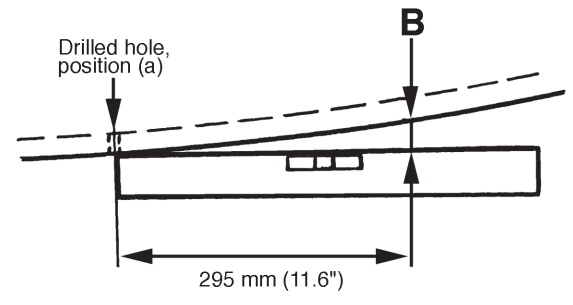

Measure distance (B).

8

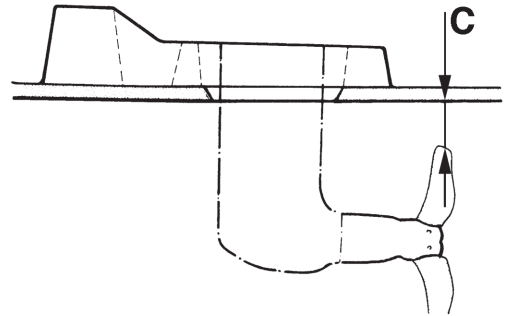

Calculate distance (C), clearance between propeller and hull.

NOTE! C must be minimum 20 mm (0.8").

**130S, 130SR
 150S, 150SR**

Formula: C = D - A + B

This gives at different propeller diameters (D):

- D=18" C=140 (5.5") -A+B
- D=19" C=128 (5.0") -A+B
- D=20" C=115 (4.5") -A+B
- D=21" C=103 (4.0") -A+B
- D=22" C= 91 (3.6") -A+B

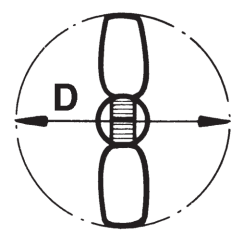

Cutting and fibreglassing of engine bed, step 9–23

9

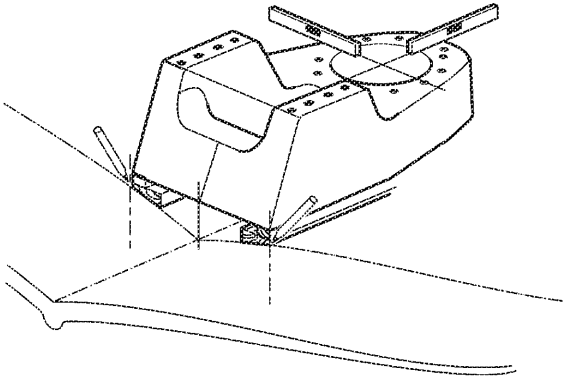

Put the bed in its position and align it so it is horizontal.

10

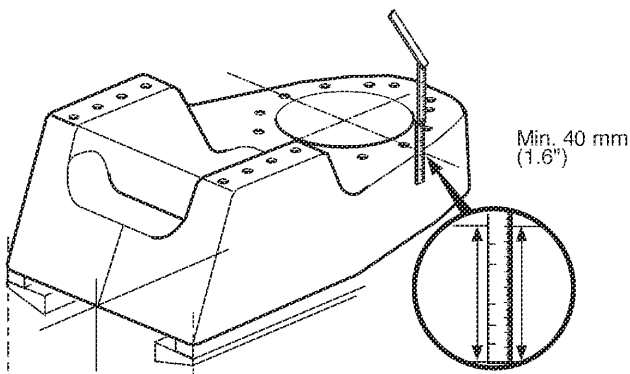

Make a marking on the bed according to figure above.

NOTE! Recommended distance: 40 mm (1.6").

11

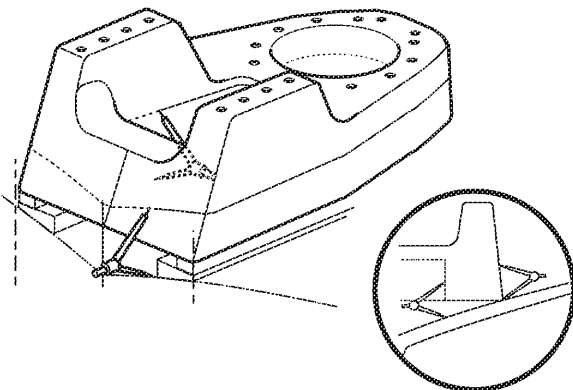

Adjust a pair of compasses to the distance between the hull and the marking made at fig. 10. Make a line around the complete bed at this height.

12

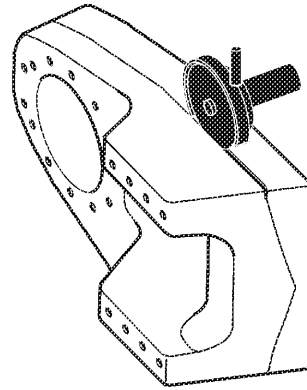

Cut the bed according to this line.

13

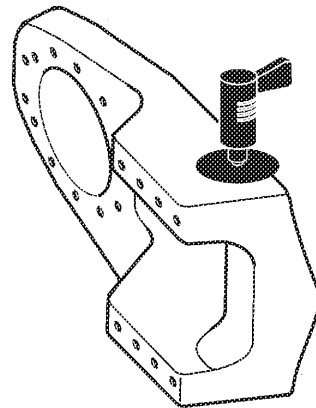

Grind off the gelcoat on the surface of the bed where there will be covered with fibre glass.

14

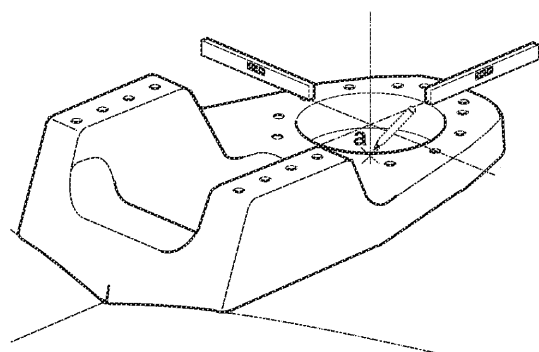

Put the bed back in the hull, position it correctly and make a marking around it.

15

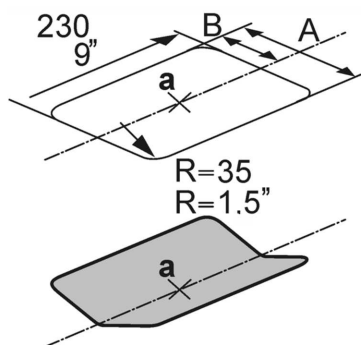

130S, 130SR
150S, 150SR
A= 125 (4.92")
B= 62.5 (2.46")

Mark up the position of the hole according to dimensions above.

18

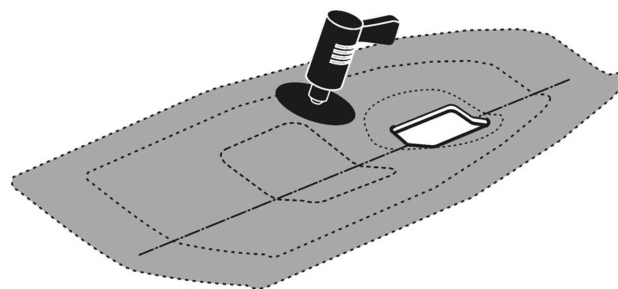

Grind off the gelcoat on the hull where it will be covered with fibre glass.

16

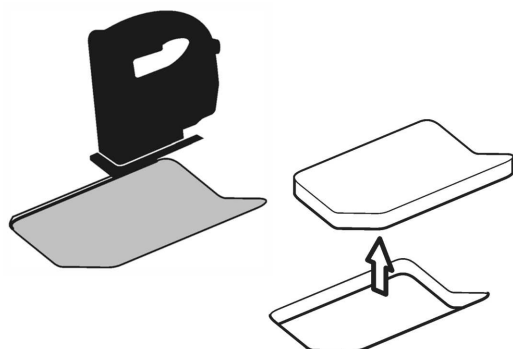

Cut the hole.

19

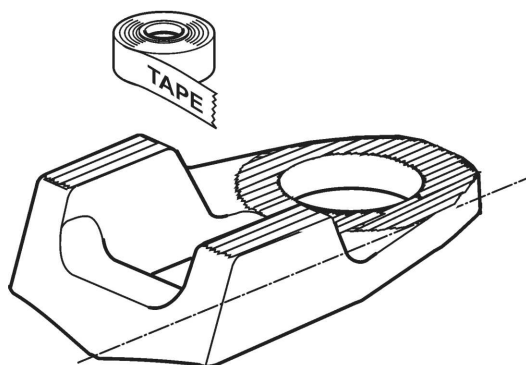

Protect the surface of the bed where the mounts and clamp ring/diaphragm will be positioned.

17

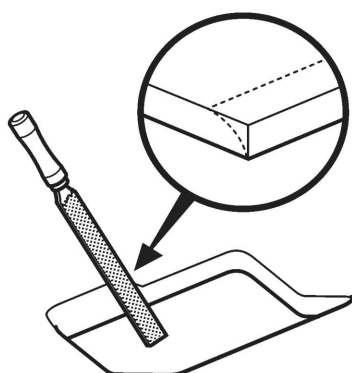

Smoothen the corner off the inside of the hull.

20

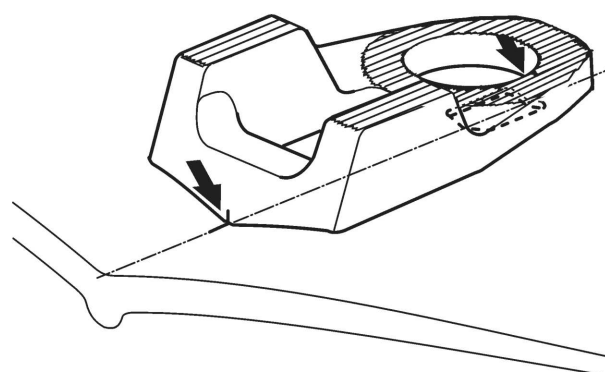

Make sure the bed is positioned correctly. Make a few markings to make sure it does not move during the bonding.

21

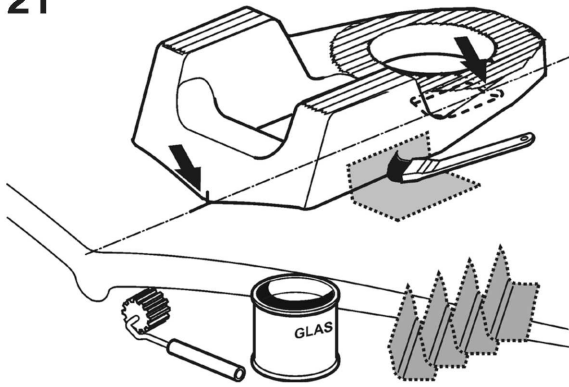

Fibre glass the bed to the hull.

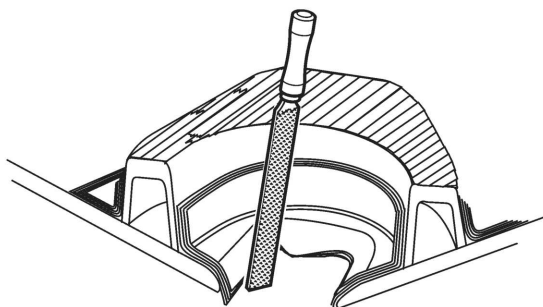
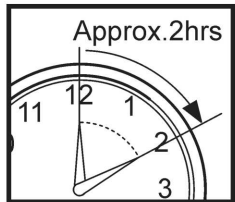
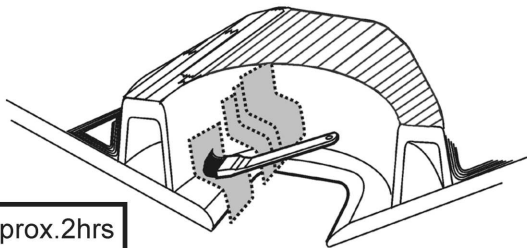

Clean off the extra fiberglass.

22



Protect the surface with top coat.

23

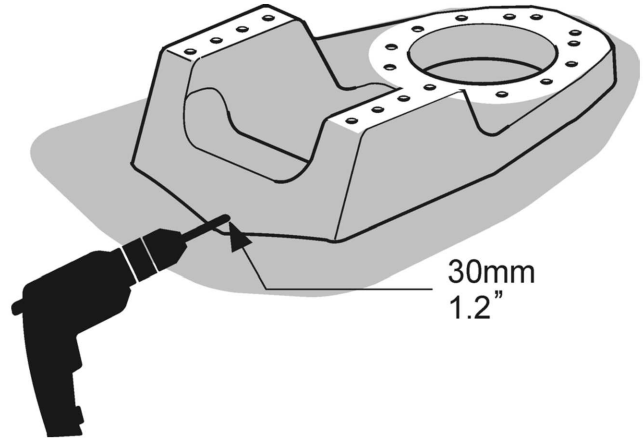

Drill a drain hole, diameter approximately 30 mm (1.2").

Installation alternative A. Drive and engine as one unit

1

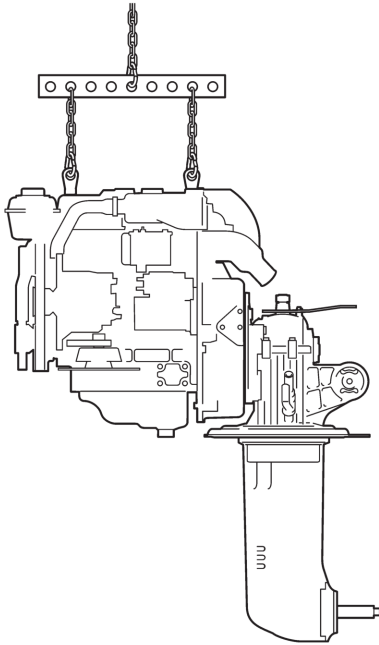

Install the S-drive to the engine.

Lift the engine and the drive onto the boat.

⚠ WARNING! Always use both lifting eyes when lifting the engine.

2

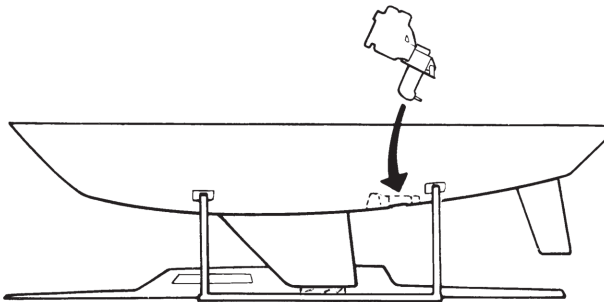

Put the clamp ring on top of the diaphragm.

Install the engine and S-drive.

3

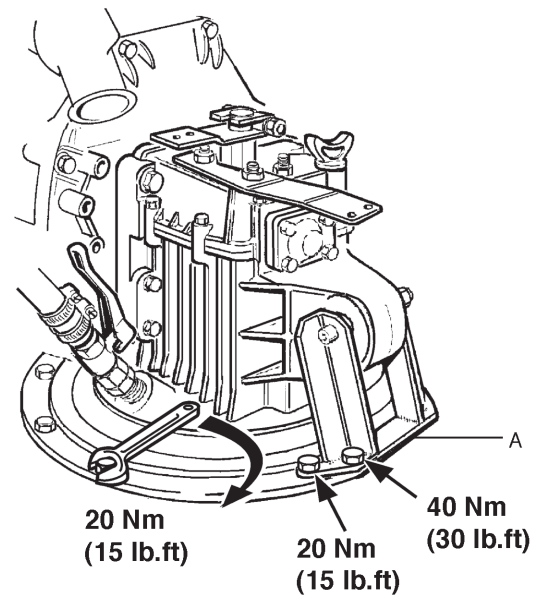

Tighten the clamp ring to the bed.

NOTE! Use no chemicals like grease, silicon etc. on the diaphragm.

Tighten the rear mount to the clamp ring.

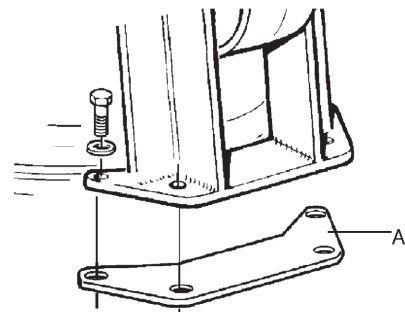

NOTE! D2-55, D2-75 only: Mount distance plate (A).

4

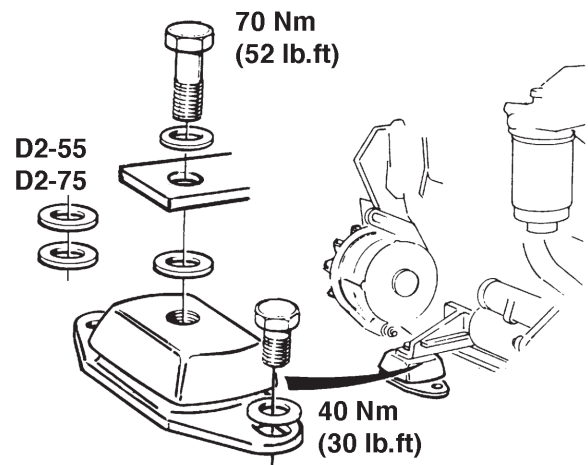

Install the front mounts.

NOTE! D2-55 and D2-75 has two washers between mount and engine bracket.

Installation alternative B. Drive and engine separated

1

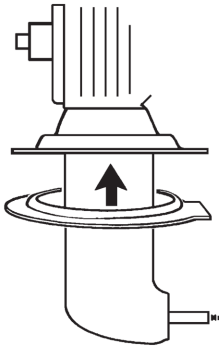

Put the clamp ring on top of the diaphragm.

2

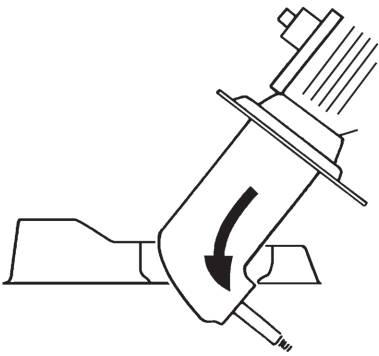

Put the S-drive through the hull.

3

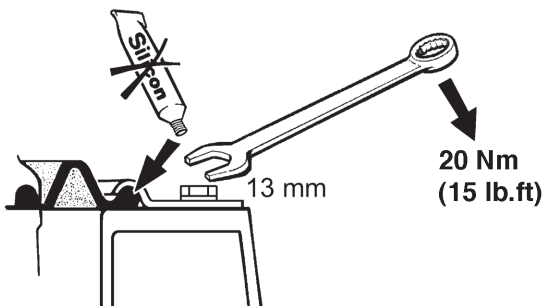

Tighten the clamp ring to the bed.

NOTE! Use no chemicals like grease, silicon etc. on the diaphragm.

Tighten the rear mount to the engine bed.

4

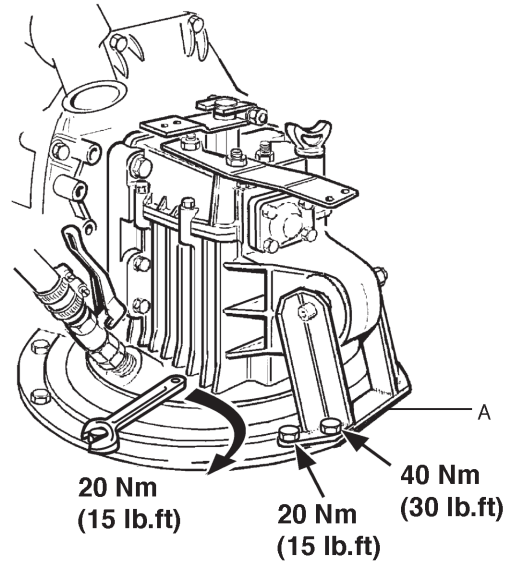

NOTE! D2-55, D2-75 only: Mount distance plate (A).

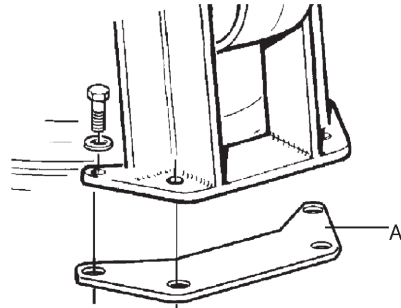

Connect the engine to the S-drive.

5

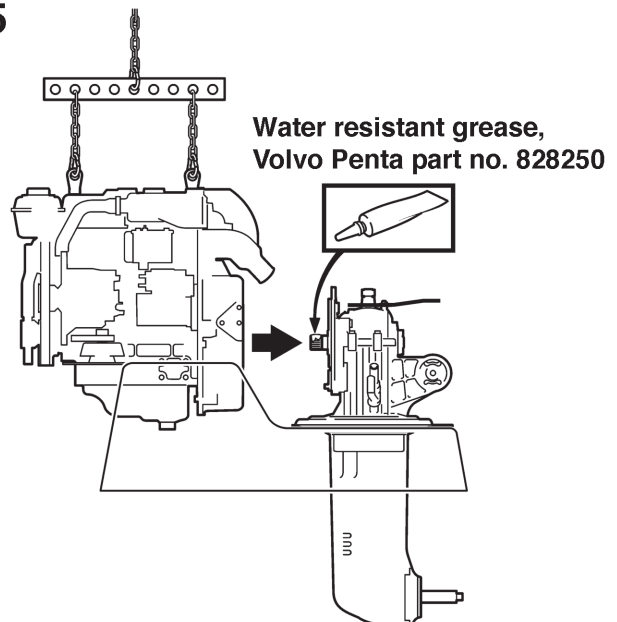

NOTE! Apply water resistant grease on output shaft splines.

⚠ WARNING! Always use both lifting eyes when lifting the engine.

Tighten the S-drive to the engine.

6

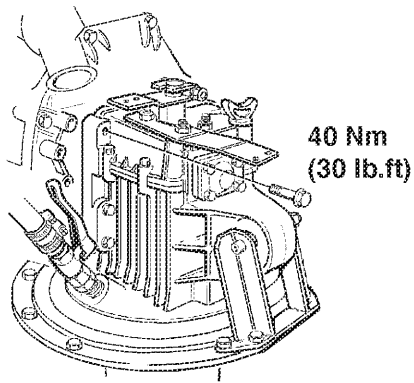

7

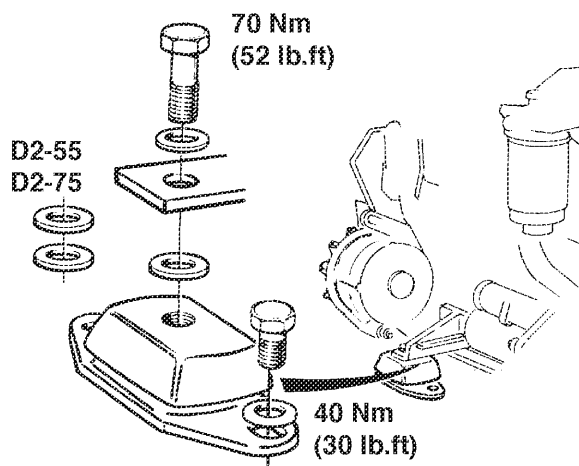

Install the front mounts.

NOTE! D2-55 and D2-75 has two washers between mount and engine bracket.

Fitting of the rubber seal

1

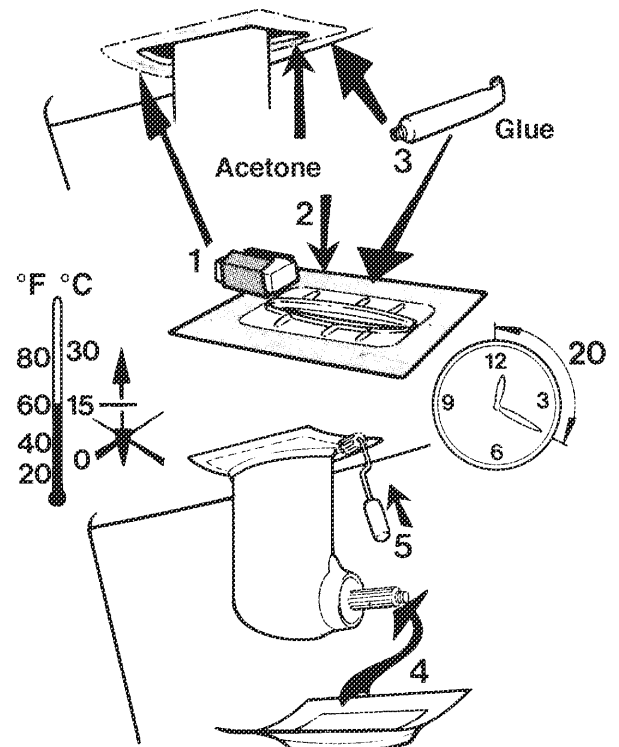

Grind the surface of the hull where the rubber seal shall be attached and the rubber seal with sandpaper. Whipe off with acetone. Glue the rubber seal to the hull.

Glue is not included in the kit. We recommend a good quality contact glue for plastic and rubber.

NOTE! Carefully follow the glue manufacturer's instructions on the package.

Installation of propeller

1

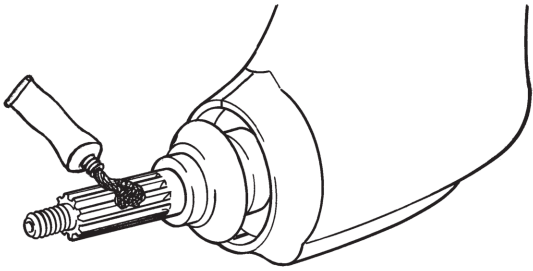

Put water resistant grease, Volvo Penta part no. 828250, on the propeller shaft.

NOTE! Use zinc sacrificial anodes for salt water and magnesium anodes for freshwater. Zinc anodes are fitted as standard.

2

Mount the propeller according to instruction

2 or 3-blade fixed

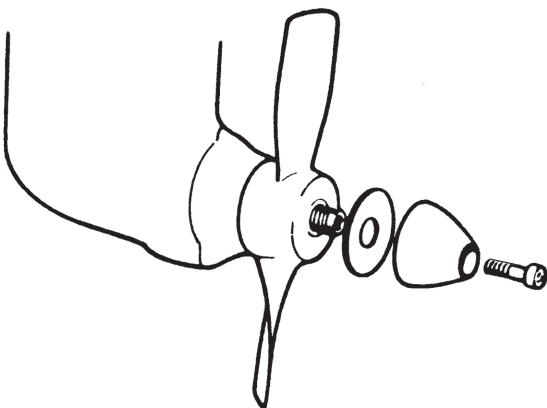

2-blade folding

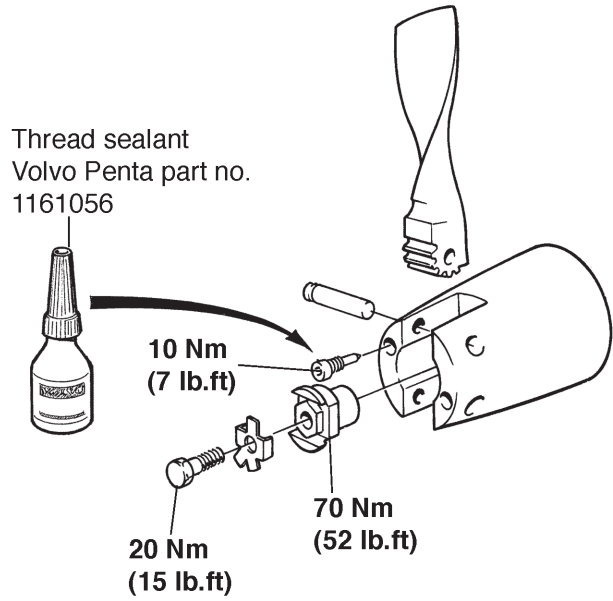

3 and 4-blade folding

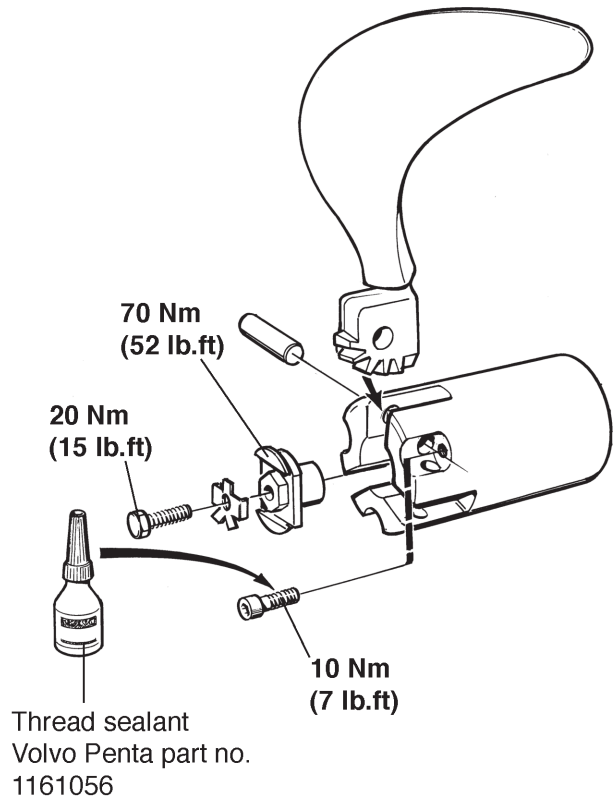

Oil quality and filling

Fill engine and S-drive with oil.
Also see Operator's manual.

Oil quality engine:
VDS-2, ACEA E5, API CH-4

Viscosity (at -5° – +50°C constant ambient air temperature) : SAE 15W/40, SAE 20W/50

Engine	Approx. volumes liters (US qts)	
D1-13	1.9	(2.0)
D1-20	2.8	(3.0)
D1-30	3.5	(3.7)
D2-40	6.0	(6.3)
D2-55	10.5	(11.0)
D2-75	10.5	(11.0)

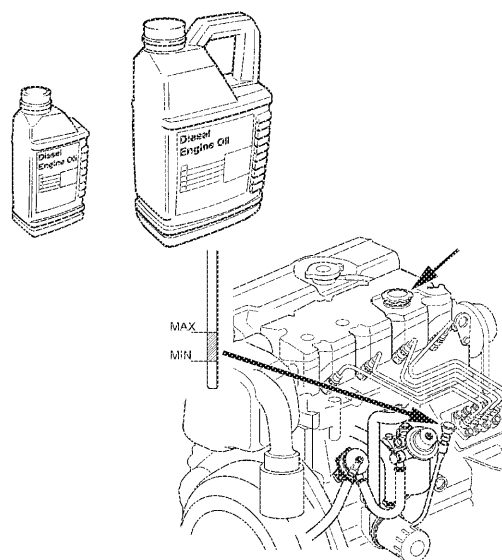

NOTE! Always check oil dipstick for final topping up.

Oil quality reverse gear:
ATF (Automatic Transmission Fluid),
Dexron II, III

Reverse gear	Volumes	
	liters	(US qts)
MS10	0.35	(0.37)
MS15	0.56	(0.59)
MS25	0.75	(0.79)
HS25	1.80	(1.90)

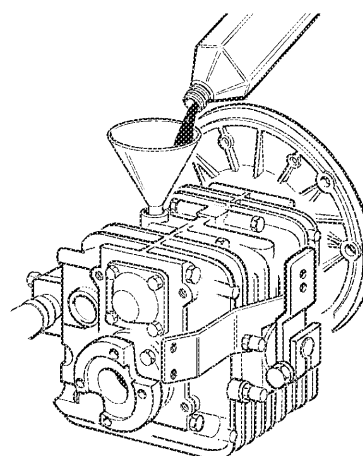

Oil quality S-drive:
ATF (Automatic Transmission Fluid),
Dexron II, III

Type	Volumes	
	liters	(US qts)
130S, SR	2.9	(3.0)
150S, SR	3.0	(3.1)

